

## Surface Mount | 707 | ZipTwo® | Remote Power | Magnet with Tape-On Metal Strip

Please read instructions in their entirety before proceeding with any part of the installation. This product must be installed in accordance with the applicable installation code by a person familiar with the construction and operation of the product and the hazards involved. Consult a qualified electrician to ensure correct branch circuit rating. To prevent electric shock, disconnect all power before installing or servicing product. Rated for use in dry and damp locations only. Retain instructions for future reference.

Technical Support: 707.996.9898 or [technicalsupport@vode.com](mailto:technicalsupport@vode.com)

---

### Installed View

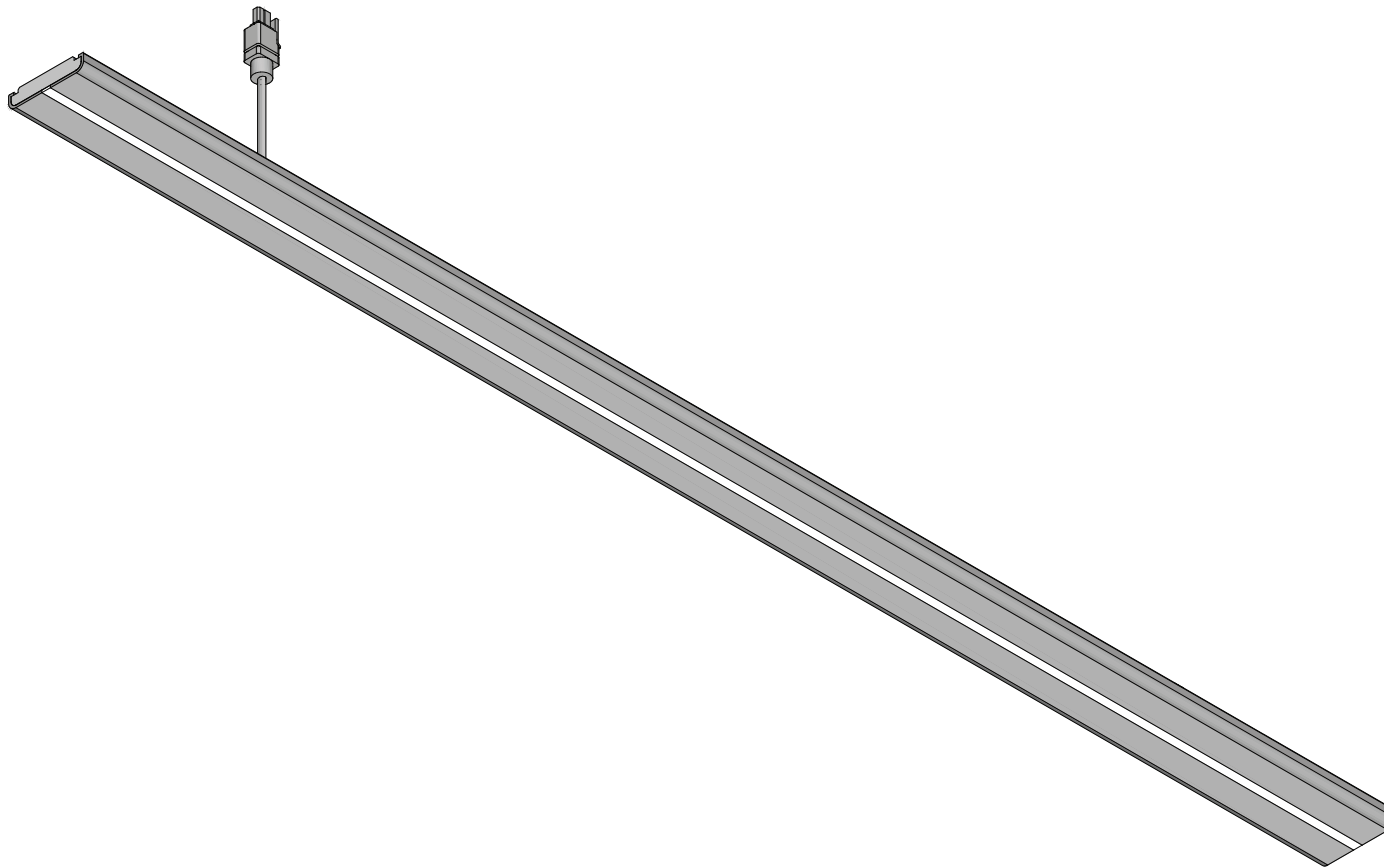

## Parts Diagram

**NOTE:** Refer to page 4 for RGBW

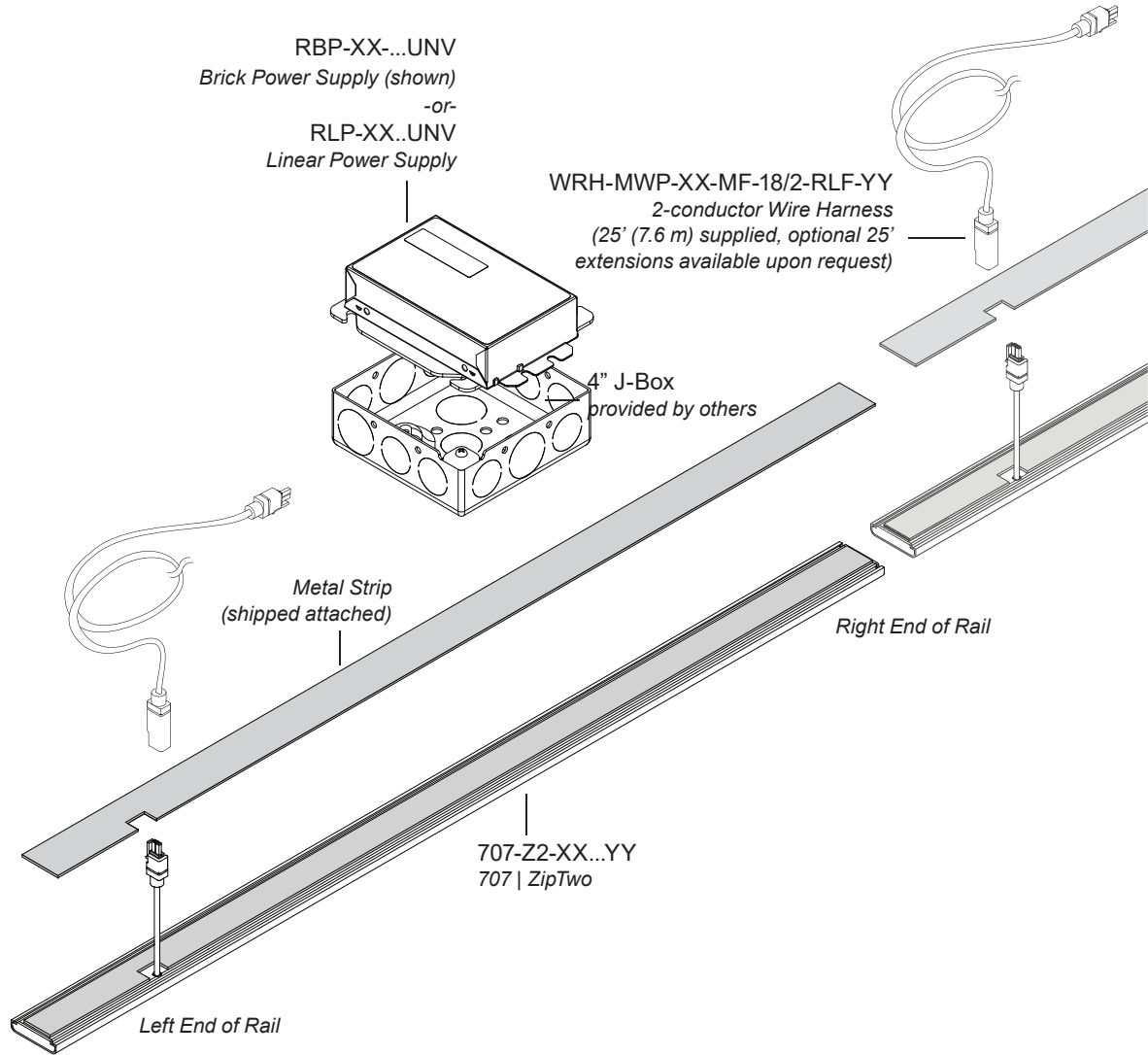

## Fixture Orientation

Power feed comes out the bottom of the fixture (as shown) and is located 3" (76 mm) in from the end of the fixture.

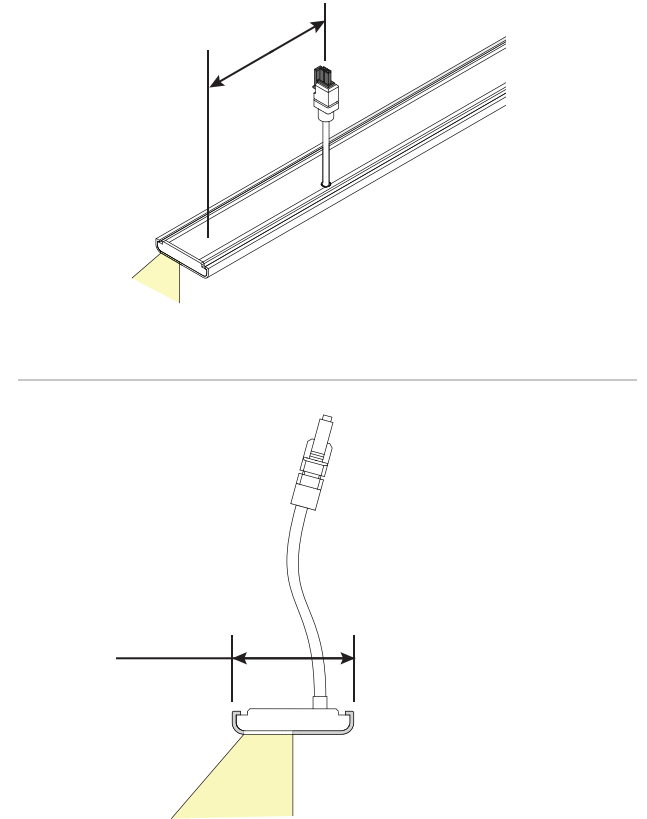

## ZipTwo Magnet with Tape-On Metal Strip Installation

Determine fixture wire harness location and drill 1/2" (13mm) hole in mounting surface. Feed low voltage wire harness into remote power housing. Connect supplied plenum rated wire harness to pre-installed wire harness on remote power supply. Leave approximately 1" of wire harness hanging out.

**IMPORTANT:** Fixture **MUST** be installed to provided ferrous strip for proper installation. Surface must be clean, dry and flat before adhering provided strip.

Remove tape-on metal strip backing and carefully apply to the desired surface. Once alignment is exactly as desired, press firmly along the length of the strip to ensure it properly secured. Connect fixture wire harness to power wire harness.

**NOTE:** Be careful with fixture orientation for the 85° Asymmetric ZipTwo Fixture.

Installation of RGBW fixtures will have 2 wire harnesses. See page 7 for more information.

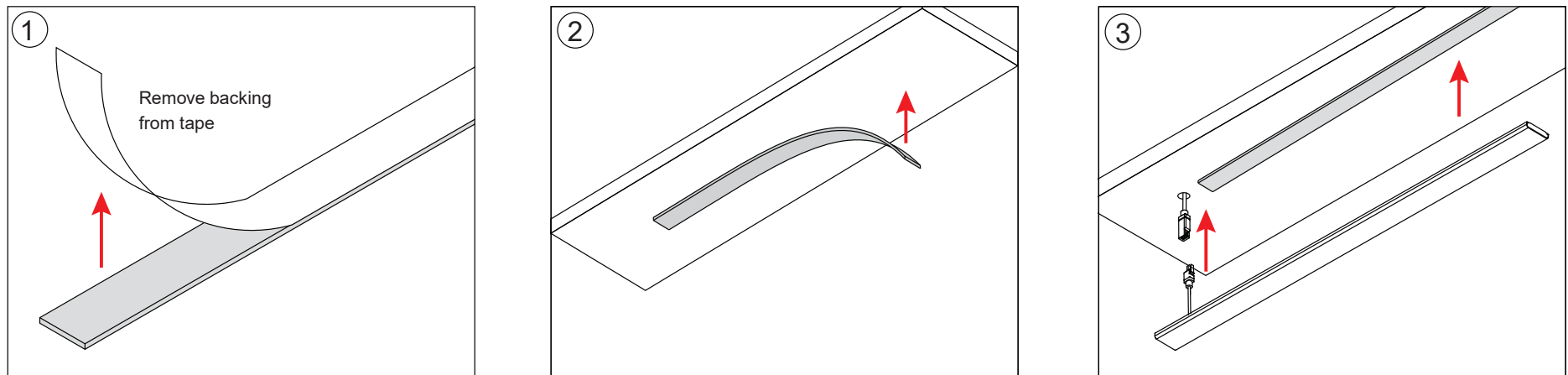

Parts Diagram for RGBW

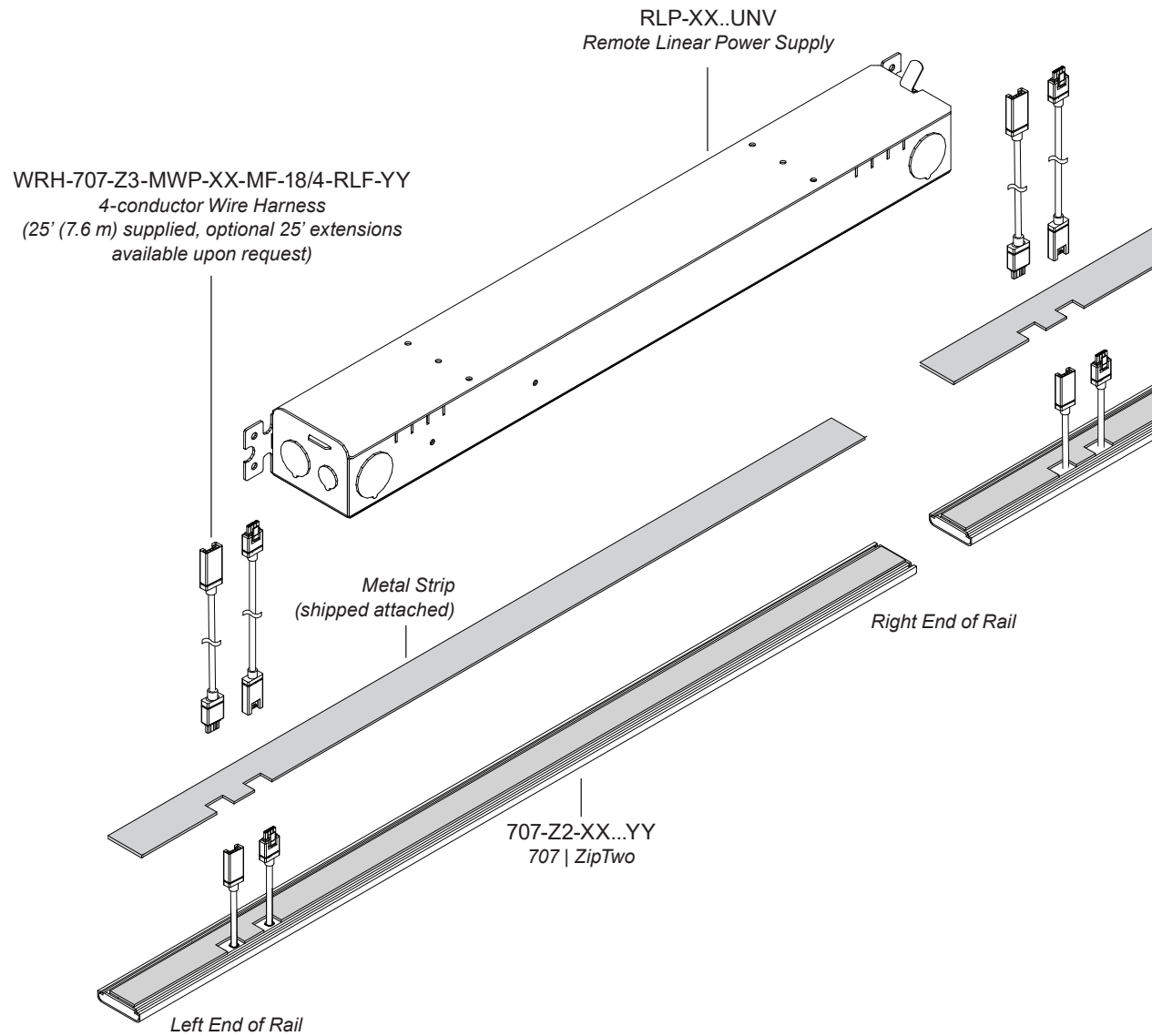

## Install Remote Brick Power Supply

**IMPORTANT!** Before installing any power supply, turn off electricity at circuit box.

**NOTE:** Vode Brick style driver mounting plate is designed to mount only to 4" Square metal j-boxes with a minimum volume of 21 cu. in. Mounting plate contains important installation labeling, please consult to ensure correct driver is installed with correct corresponding rail.

Install j-box (*provided by others*) to desired surface using screws (*provided by others*). Run line, ground and neutral wiring and any applicable dimming controls into j-box through knockout and secure in place, using conduit as necessary per local coding. Use wire nuts (*provided by others*) to make a secure connection between all wiring. (*The provided wire leads are 18 AWG solid core*).

**DO NOT** power on system until instructed.

For remote power supply maximum distance or wiring questions, please consult **Vode Remote Power Guide**.

**NOTE:** If power housing is supplied pre-wired with cord and plug and wire harness installed, skip above steps and power system when instructed by plugging system into a standard outlet.

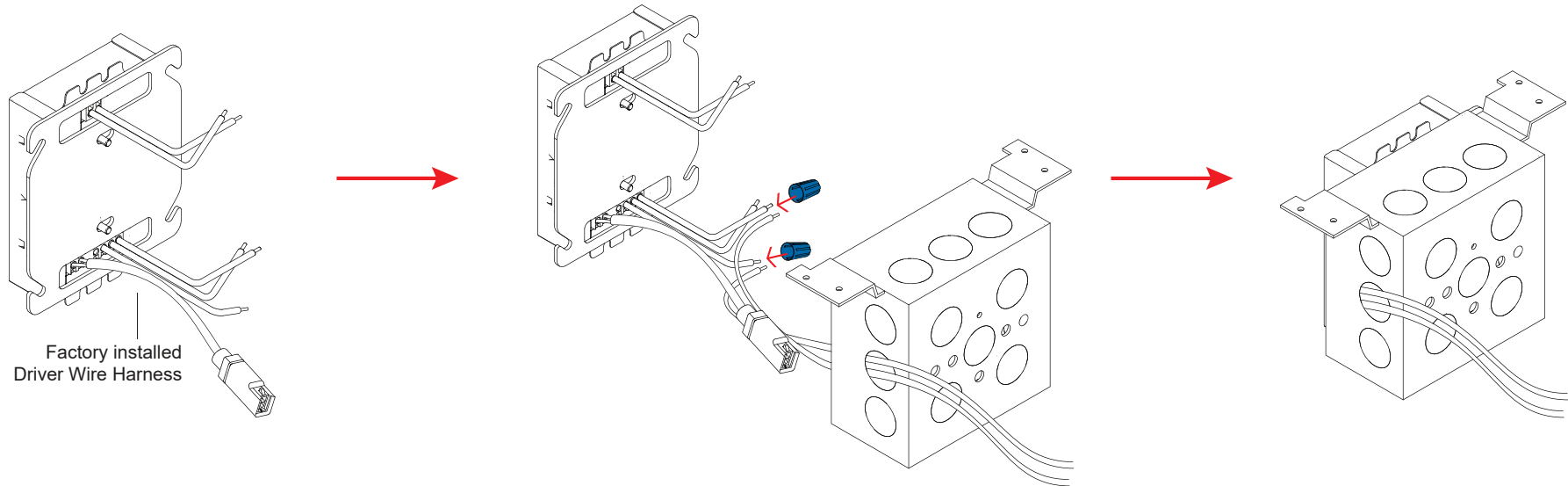

## Max Remote Driver Distance

Driver	Remote Distance
eldoLED	100' (30.5 m)
Lutron	<b>See Vode Power Guide</b>

For other wiring questions and driver specific information, see **Vode Remote Power Guide**.

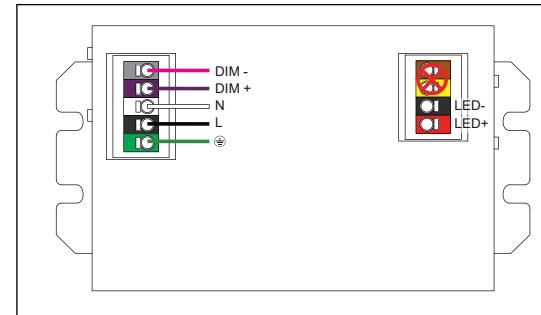

**Example Only**  
See Vode Remote Power Guide for wiring detail.

## Install Remote Linear Power Supply

**IMPORTANT!** Before installing any power supply, turn off electricity at circuit box.

Vode recommends keeping track of which lids comes with which housing, as the lid contains important installation labeling.

Using the indicated tab, remove power housing lid to access mounting points. Install power supply housing to desired surface using screws (*provided by others*). Run line, ground and neutral wiring and any applicable dimming controls into power housing through any provided knockout and secure in place, using conduit as necessary per local coding. Use wire nuts (*provided by others*) to make a secure connection between all wiring. (*The provided wire leads are 18 AWG solid core*).

**DO NOT** power on system until instructed.

For remote power supply maximum distance or other wiring questions, please consult Vode Power Guide.

**NOTE:** If power housing is supplied pre-wired with cord and plug and wire harness installed, skip above steps and power system when instructed by plugging system into a standard outlet.

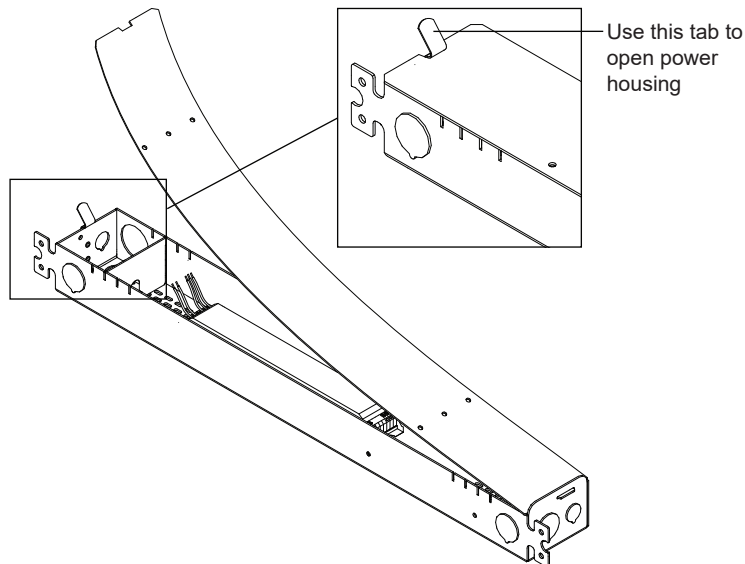

## Remote Driver Distance

All Vode linear remote drivers come in a 0.054" (1.4 mm) formed galvanized steel power supply housing with five (5) knockouts: (4) 1-1/8", (1) 7/8" and (1) 9/16". Power supply housing dimensions: 2 3/8" (56 mm) x 1 5/8" (33 mm) x 20 1/16" (525 mm)

Driver	Remote Distance
eldoLED	100' (30.5 m)
Lutron	<b>See Power Guide</b>
Magnitude	100' (30.5 m)
OSRAM	100' (30.5 m)

For other wiring questions and driver specific information, see **Vode Remote Power Guide**.

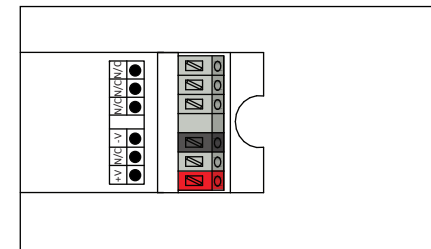

**Example Only**  
See Vode Remote Power Guide for wiring detail.

## Trouble Shooting Guide

### My fixture will not turn on:

---

Check all wiring is correct and all connections are fastened properly.

If all wiring is correct, remove fixture and connect it to a known working driver.

If the fixture lights up, then the problem is with the installed driver or wiring:

- 1) Check line voltage to driver is present.
- 2) Check driver wiring (see **Vode Power Guide for details**) and check wiring to fixture.
- 3) Check driver and dimming system are compatible (see **Vode Power Guide and the dimmer manufacturer's website**).

If fixture still doesn't light up, check that all dimming wires are installed correctly. Reversed polarity on any driver will cause the entire system to not work, (see **Vode Power Guide for wiring details**).

### The fixture is not dimming properly:

---

Check all wiring is correct and all connections are fastened properly.

Check driver wiring (see **Vode Power Guide for details**). Make sure driver is compatible with dimming controls (see **Vode Power Guide and the dimmer manufacturer's website**).

---

**For any help with installation or technical information, contact Vode Tech Service at 707-996-9898.**

## Important Notes

---

- Listed to UL standards for damp location by a Nationally Recognized Testing Laboratory (NRTL) recognized by OSHA
- Power Type: Class 2 (<60v) constant current driver.
- Dimming curve is factory preset to linear. Logarithmic is available upon request. See Vode Driver Guide for specific details and wiring diagram.
- Unless specified, one driver per rail will be supplied.
- 5 Year Limited Warranty. All material and component parts manufactured by Vode are guaranteed to be free from defects of material and/or workmanship for a period of 5 years from date of sale. Product must be installed according to Vode installation instructions and accepted trade practices. Power supplies and other auxiliary equipment are not covered under Vode warranty but may be covered by separate OEM warranty.
- Any modifications, alterations, or unauthorized adjustments to the wire harness, including but not limited to cutting or splicing, outside of its original factory configuration will void all warranties.