

Surface Mount | 707 | Wedge™ | Remote Power | Clip with Micro-Jbox

Please read instructions in their entirety before proceeding with any part of the installation. This product must be installed in accordance with the applicable installation code by a person familiar with the construction and operation of the product and the hazards involved. Consult a qualified electrician to ensure correct branch circuit rating. To prevent electric shock, disconnect all power before installing or servicing product. Rated for use in dry and damp locations only. Retain instructions for future reference.

Technical Support: 707.996.9898 or technicalsupport@vode.com

Installed View

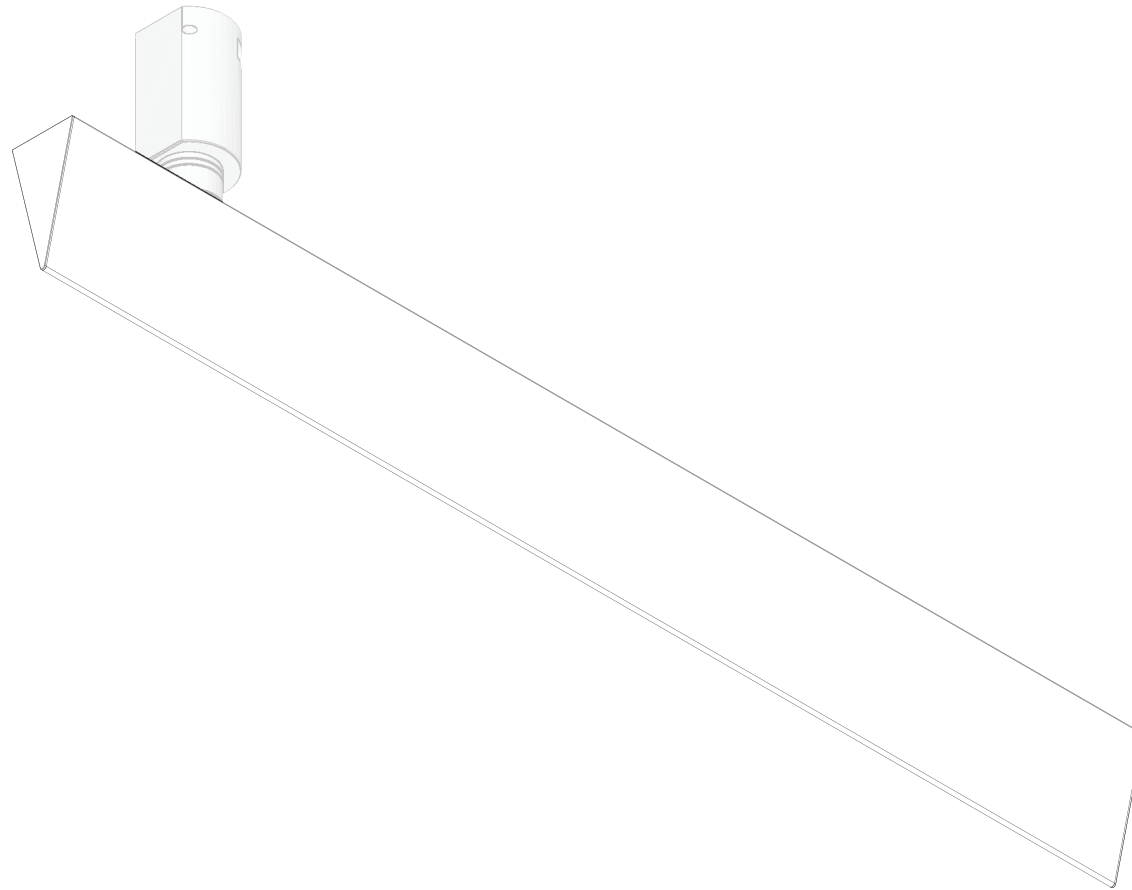

Parts Diagram

Step 2: Install Wire Harness

WRH-MWP-XX-MF-18/2-RLF-YY
2-conductor Wire Harness
(25' (7.6 m) supplied, optional 25'
extensions available upon request)

Step 4: Install Clips and Fixture

CS-707-Z2
707 | ZipTwo & Wedge Clip

Step 2: Install Wire Harness

RBP-XX-...UNV
Brick Power Supply (shown)
-or-
RLP-XX..UNV
Linear Power Supply

4" J-Box
provided by others

CS-00006
707 | ZipTwo & Wedge Joiner

Step 1: Install Micro J-Box

JB-707-Z2-MC-AL
Micro J-Box

Right End of Rail

Step 4: Install Clips and Fixture

707-Z2-XX...YY
707 | Wedge

Left End of Rail

Wedge Joiner

A Joiner clip is provided to align rails for a continuous Wedge system. Install Joiner clips to rails before mounting rails to the mounting clips.

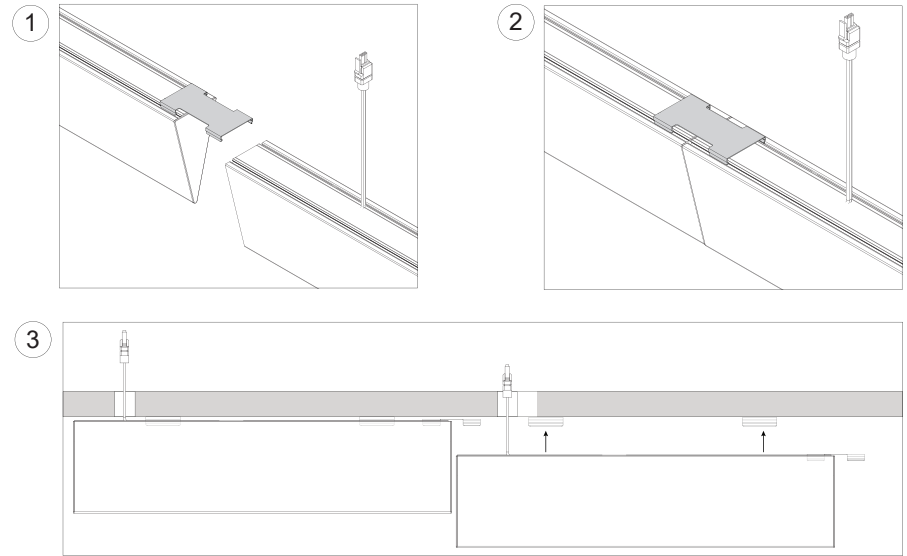

Fixture Orientation

Power feed comes out the bottom of the fixture (as shown) and is located 3" (76 mm) in from the end of the fixture. For 85° optics, power feed is located on the right side of the fixture, when facing the illuminated surface.

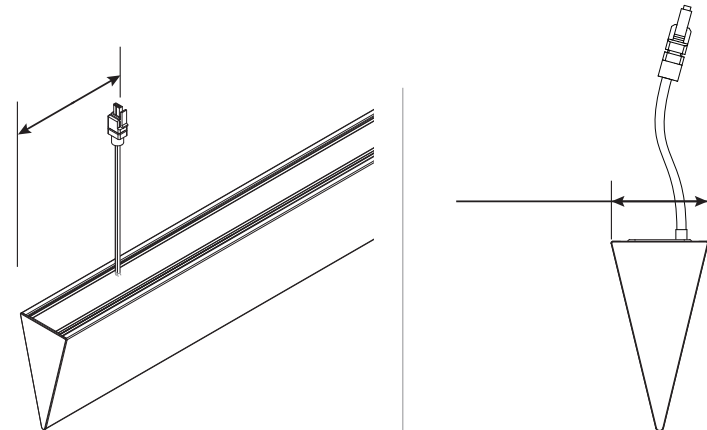

Step 1: Install Micro J-Box

Accurate placement and alignment of Micro J-Box is very important. It is not adjustable once installed. Micro J-Box has guide lines for 5/8" and 1/2" drywall.

J-box location is always 3" on-center from the end of the fixture, unless otherwise specified. Install one Micro J-Box per fixture.

NOTE: Be careful with fixture orientation for the 85° Asymmetric Wedge Fixture. See page 2 for more information.

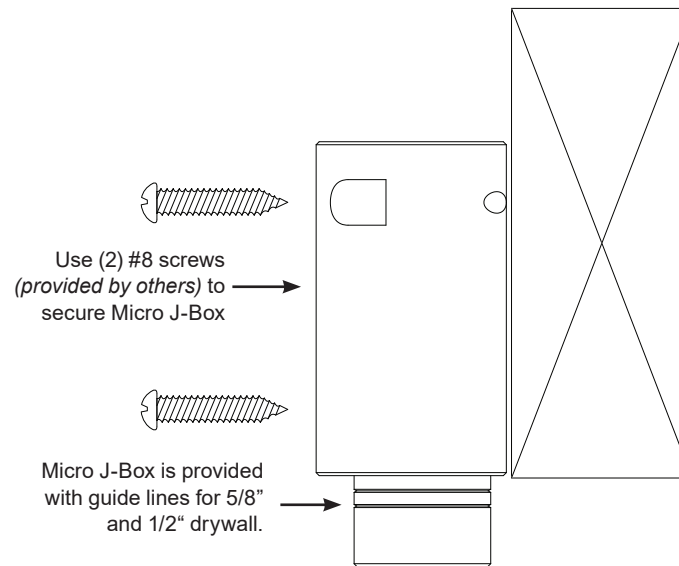

Step 2: Install Power Supply

IMPORTANT! If system will be supplied with a brick driver, j-boxes will be not be provided.

Refer to appendix for installation of remote power housing.

Feed low voltage wire harness into remote power housing. Connect supplied plenum rated wire harness to pre-installed wire harness on remote power supply and run to j-box.

For remote power supply maximum distance or other wiring questions, please consult Vode Power Guide.

Run conduit from remote power supply to Micro J-Box, if required. Micro J-Box has two 3/4" female NPT holes for conduit fittings, *provided by others*.

Remove the provided red plug and feed low voltage wire harness through Micro J-Box and conduit into remote power housing, leaving enough for approximately 1" of wire harness to be hanging out of Micro J-Box. Coil the wire hanging connector back into the Micro J-Box and **replace the red plug**.

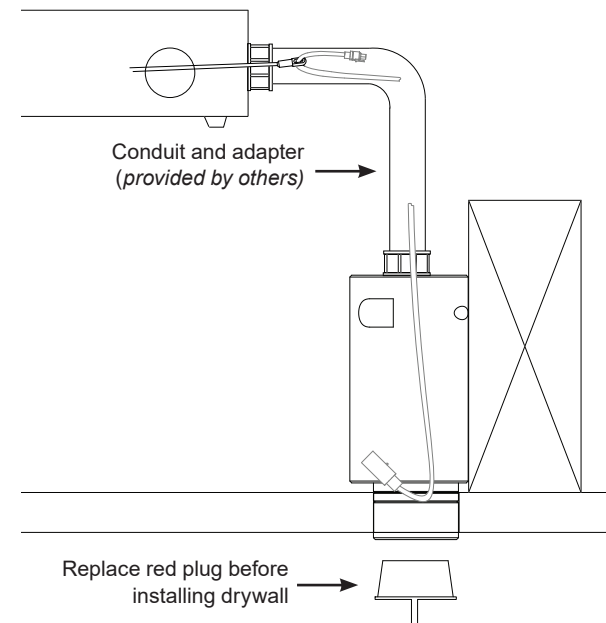

DO NOT POWER ON

Step 3: Install Drywall

Drill 1 1/8" hole for Micro J-Box opening and install drywall. Mud to edge of opening as necessary and remove red plug when dry.

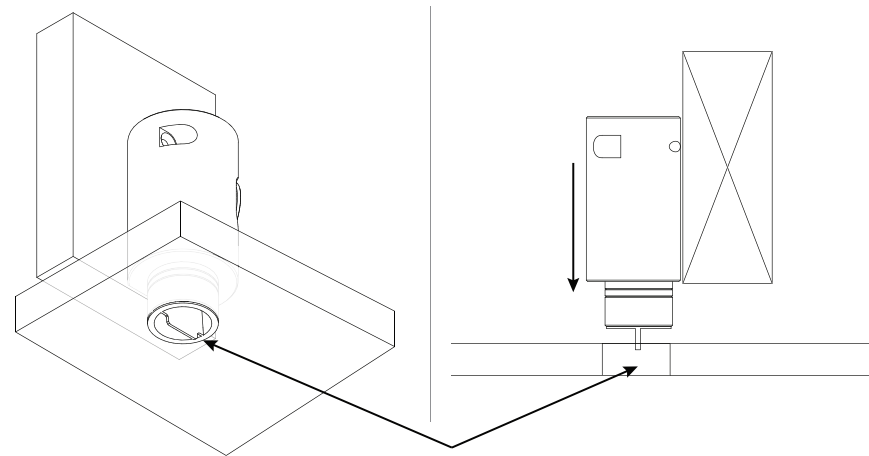

Drill a 1 1/8" (29 mm) hole for the Micro J-box. Remove red plug after mud dries.

Step 4: Install Power Supply

Install clips using provided 5/8" screws. Fixtures will be supplied with two clips for rails under 48", four clips for rails 48" to 72" and six clips for 96" rails. Position one clip 4" (102mm) from the end of the fixture opposite from the Micro J-box and evenly space the remaining clips.

Run fixture cable through Micro J-Box fixture clip and connect fixture wire harness to power wire harness. Insert Micro J-Box fixture clip flanges into Micro J-Box so it is flush with drywall surface. Insert fixture onto installed clips by inserting back edge of fixture to installed clips, then carefully snapping front edge on. For multi-rail systems, see Wedge Joiner instructions, page 2.

NOTE: Be careful with fixture orientation for the 85° Asymmetric Wedge Fixture. For 85° optics, power feed is located on the left side of the fixture, when facing the illuminated surface. See page 2 for more information.

Power system **ON**

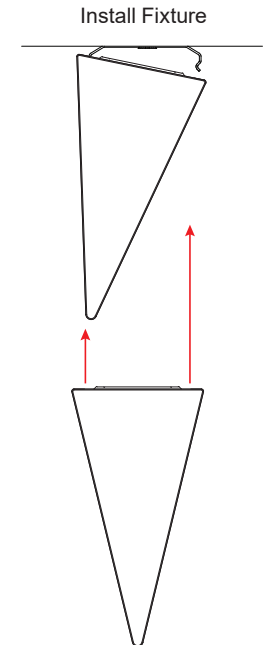
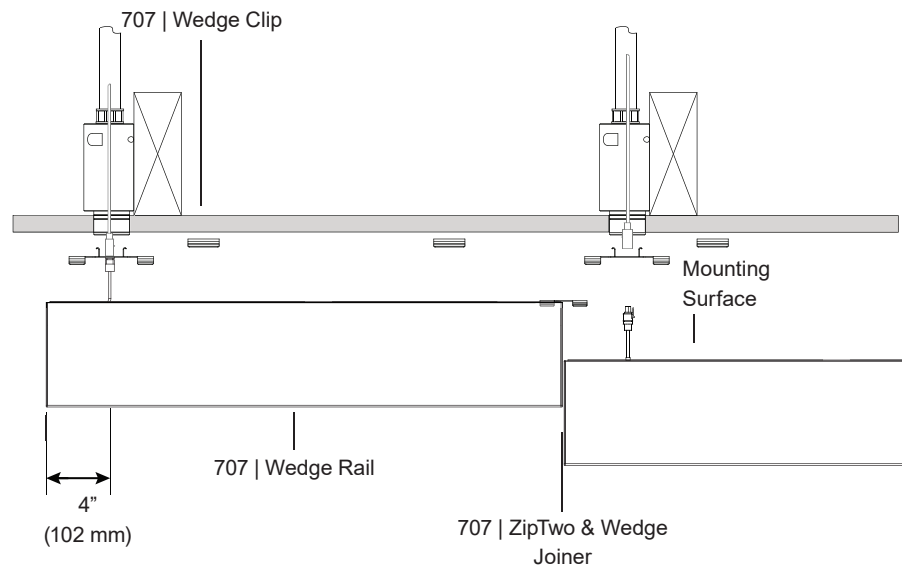

Install Remote Brick Power Supply

IMPORTANT! Before installing any power supply, turn off electricity at circuit box.

NOTE: Vode Brick style driver mounting plate is designed to mount only to 4" Square metal j-boxes with a minimum volume of 21 cu. in. Mounting plate contains important installation labeling, please consult to ensure correct driver is installed with correct corresponding rail.

Install j-box (*provided by others*) to desired surface using screws (*provided by others*). Run line, ground and neutral wiring and any applicable dimming controls into j-box through knockout and secure in place, using conduit as necessary per local coding. Use wire nuts (*provided by others*) to make a secure connection between all wiring. (*The provided wire leads are 18 AWG solid core*).

DO NOT power on system until instructed.

For remote power supply maximum distance or wiring questions, please consult **Vode Remote Power Guide**.

NOTE: If power housing is supplied pre-wired with cord and plug and wire harness installed, skip above steps and power system when instructed by plugging system into a standard outlet.

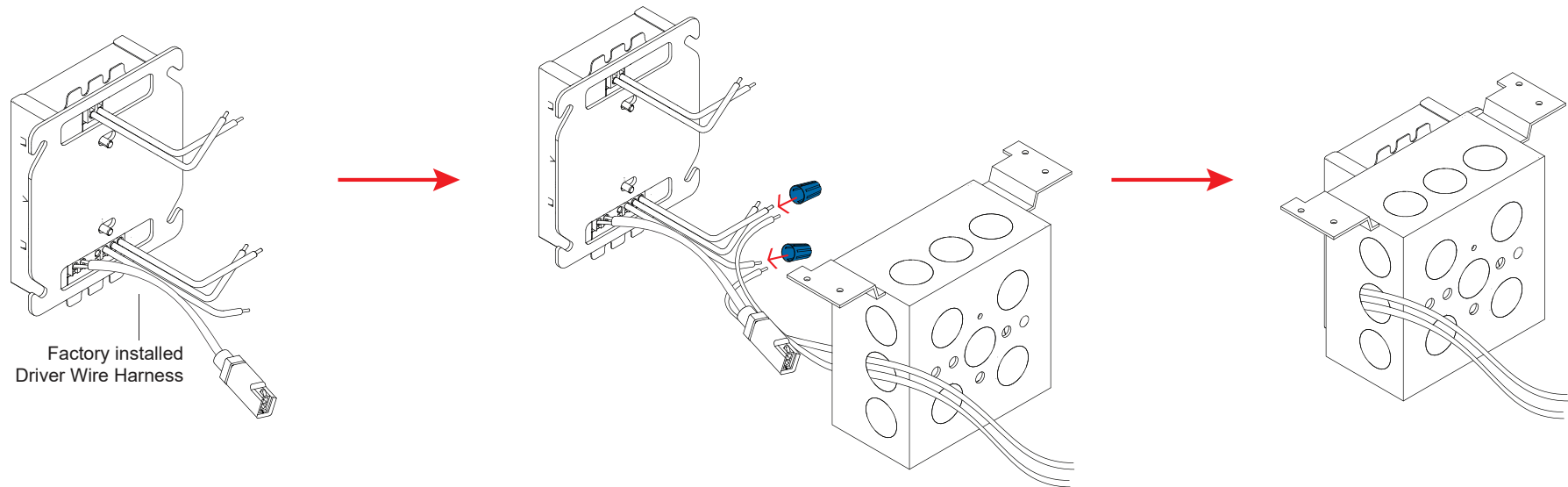

Max Remote Driver Distance

Driver	Remote Distance
eldoLED	100' (30.5 m)
Lutron	See Vode Power Guide

For other wiring questions and driver specific information, see **Vode Remote Power Guide**.

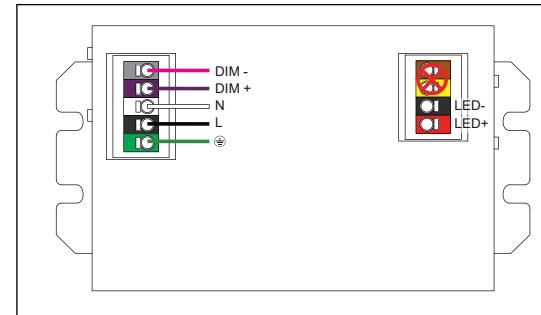

Example Only

See *Vode Remote Power Guide* for wiring detail.

Install Remote Linear Power Supply

IMPORTANT! Before installing any power supply, turn off electricity at circuit box.

Vode recommends keeping track of which lids comes with which housing, as the lid contains important installation labeling.

Using the indicated tab, remove power housing lid to access mounting points. Install power supply housing to desired surface using screws (*provided by others*). Run line, ground and neutral wiring and any applicable dimming controls into power housing through any provided knockout and secure in place, using conduit as necessary per local coding. Use wire nuts (*provided by others*) to make a secure connection between all wiring. (*The provided wire leads are 18 AWG solid core*).

DO NOT power on system until instructed.

For remote power supply maximum distance or other wiring questions, please consult Vode Power Guide.

NOTE: If power housing is supplied pre-wired with cord and plug and wire harness installed, skip above steps and power system when instructed by plugging system into a standard outlet.

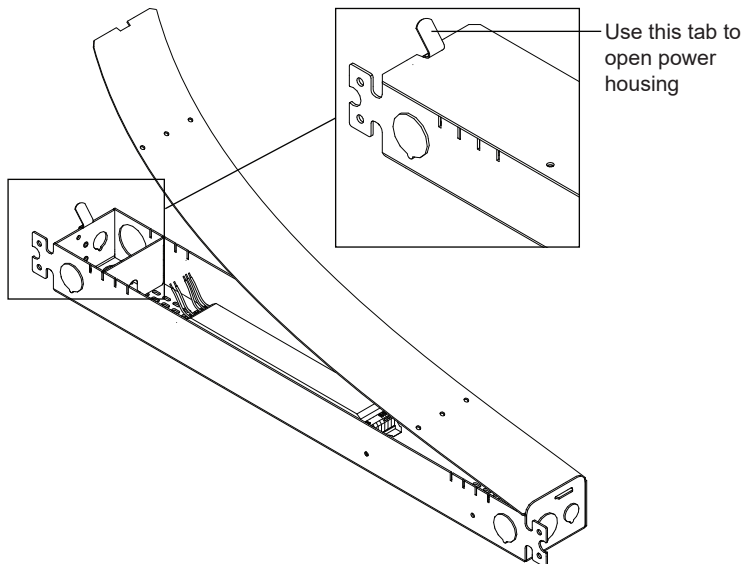

Remote Driver Distance

All Vode linear remote drivers come in a 0.054" (1.4 mm) formed galvanized steel power supply housing with five (5) knockouts: (4) 1-1/8", (1) 7/8" and (1) 9/16". Power supply housing dimensions: 2 3/8" (56 mm) x 1 5/8" (33 mm) x 20 1/16" (525 mm)

Driver	Remote Distance
eldoLED	100' (30.5 m)
Lutron	See Power Guide
Magnitude	100' (30.5 m)
OSRAM	100' (30.5 m)

For other wiring questions and driver specific information, see **Vode Remote Power Guide**.

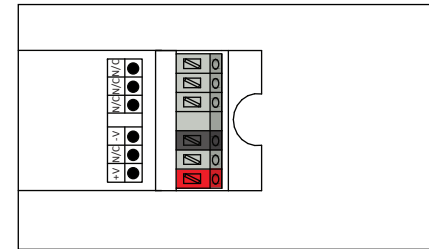

Example Only
See Vode Remote Power Guide for wiring detail.

Trouble Shooting Guide

My fixture will not turn on:

Check all wiring is correct and all connections are fastened properly.

If all wiring is correct, remove fixture and connect it to a known working driver.

If the fixture lights up, then the problem is with the installed driver or wiring:

- 1) Check line voltage to driver is present.
- 2) Check driver wiring (see **Vode Power Guide for details**) and check wiring to fixture.
- 3) Check driver and dimming system are compatible (see **Vode Power Guide and the dimmer manufacturer's website**).

If fixture still doesn't light up, check that all dimming wires are installed correctly. Reversed polarity on any driver will cause the entire system to not work, (see **Vode Power Guide for wiring details**).

The fixture is not dimming properly:

Check all wiring is correct and all connections are fastened properly.

Check driver wiring (see **Vode Power Guide for details**). Make sure driver is compatible with dimming controls (see **Vode Power Guide and the dimmer manufacturer's website**).

For any help with installation or technical information, contact Vode Tech Service at 707-996-9898.

Important Notes

- Listed to UL standards for damp location by a Nationally Recognized Testing Laboratory (NRTL) recognized by OSHA
- Power Type: Class 2 (<60v) constant current driver.
- Dimming curve is factory preset to linear. Logarithmic is available upon request. See Vode Driver Guide for specific details and wiring diagram.
- Unless specified, one driver per rail will be supplied.
- 5 Year Limited Warranty. All material and component parts manufactured by Vode are guaranteed to be free from defects of material and/or workmanship for a period of 5 years from date of sale. Product must be installed according to Vode installation instructions and accepted trade practices. Power supplies and other auxiliary equipment are not covered under Vode warranty but may be covered by separate OEM warranty.