

Ceiling-Wall Arm | 107 | **Integral Power DMX**

BoxRail[®], RaceRail[®], WingRail[®] | 107

Please read instructions in their entirety before proceeding with any part of the installation. This product must be installed in accordance with the applicable installation code by a person familiar with the construction and operation of the product and the hazards involved. Consult a qualified electrician to ensure correct branch circuit rating. To prevent electric shock, disconnect all power before installing or servicing product. Rated for use in dry and damp locations only. Retain instructions for future reference.

Technical Support: 707-996-9898 or technicalsupport@vode.com

Installed View

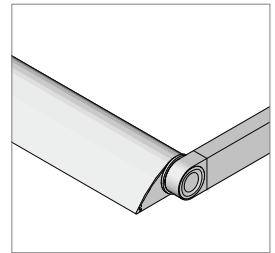
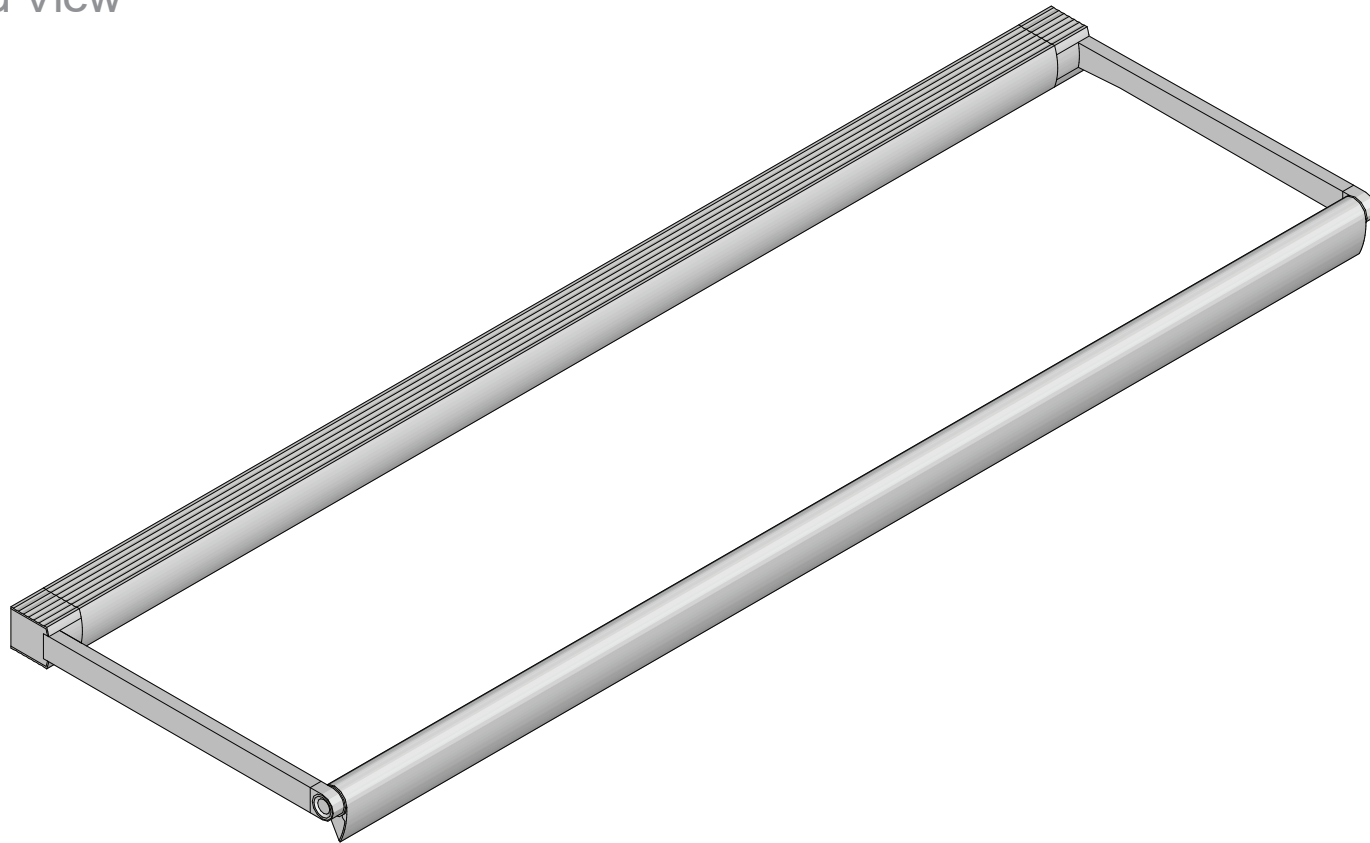

WingRail

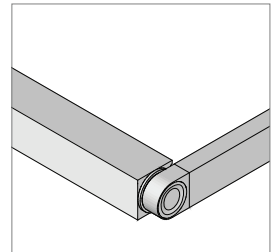

BoxRail

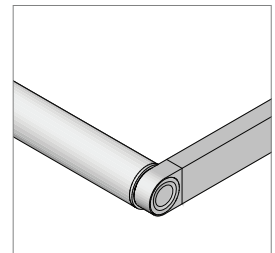

RaceRail

Parts Diagram

NOTE: Single rail systems do not have any double mounting components.

NOTE: WingRail rail orientation is very important. Be sure wire harness connection (power) is on the right side of the rail and it is oriented as shown.

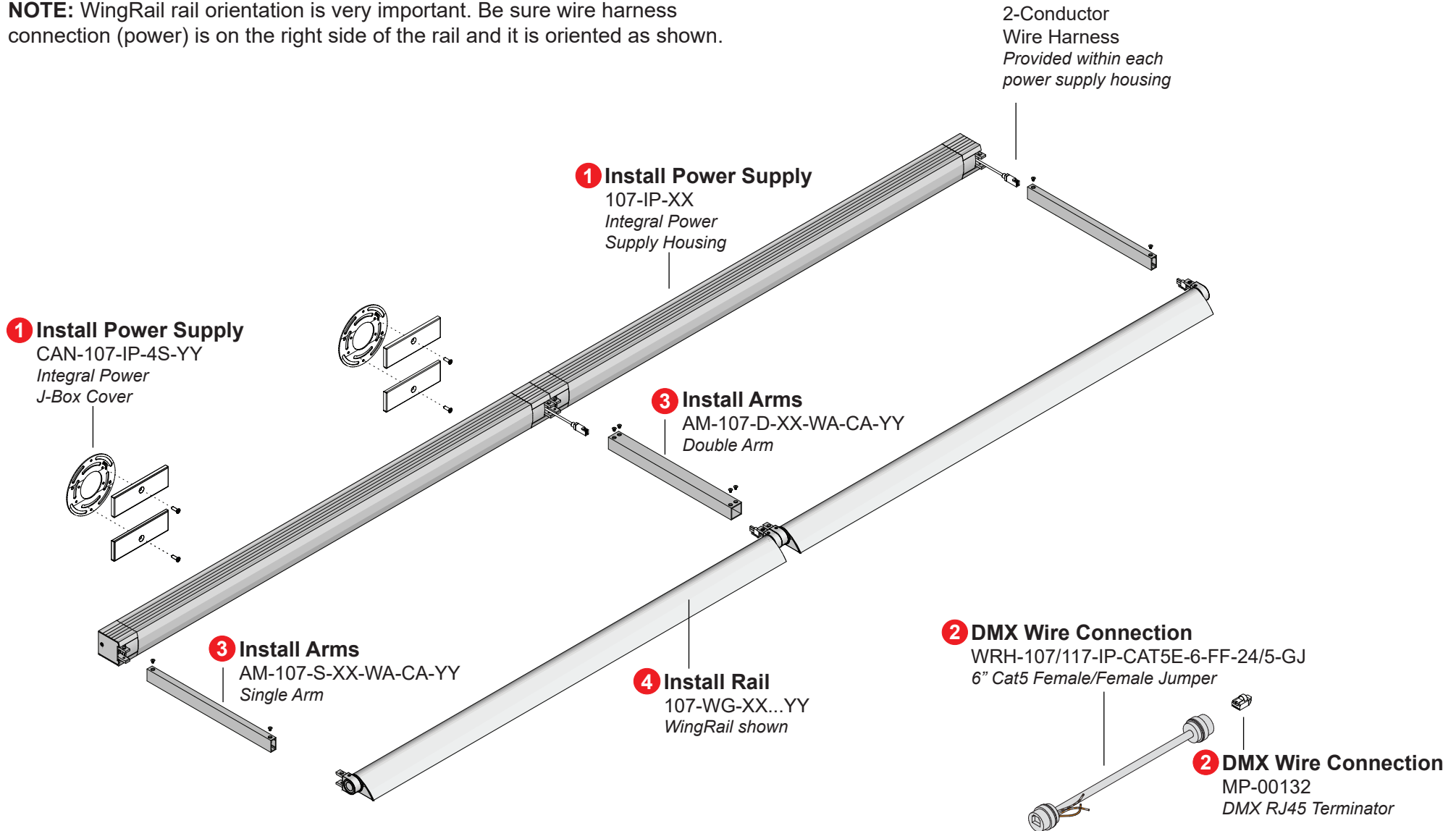

Installation Instructions

1 Mount Integral Power Housing and Make Line Voltage Connections

IMPORTANT: The power housing must be installed in the correct orientation. The driver is located on the right end of the housing. Housing cover should be installed with screws on top of housing for wall mount applications, or in the least visible position for ceiling mount applications. DMX and power wiring must be brought in through one of the end sections, not through any middle sections.

Measure and mark layout for entire system before installing. Remove integral power housing cover carefully to avoid damaging the finish. Match each cover to its housing to ensure proper fit during assembly. Integral power housings are supplied with knock-out holes for ½" NPT fittings, see page 8 for knock-out hole locations.

For Multi-Rail systems: Multi-rail systems typically only require one power feed, depending on overall length and output settings. Install first integral power housing as described above. Install the next power housing flush to the first housing. Make line voltage power connections to quick disconnect provided by Vode. Each Power Housing is provided with a quick disconnect to bring power in wherever desired. Make power harness connections on all joint-sections using provided White/Green/Black power harnesses for power. Make sure mating connectors are completely secured to ensure that system will work properly. Make sure additional back-plate sections are leveled with first section before securing additional section to surface. Make sure joint end-blocks are tight and even to ensure a straight installation. Double arms may be used to help align housings.

Powering System Using Direct Conduit Feed (*multi-rail system shown*):

Drill a ¾" (19 mm) hole in mounting surface behind power housing for each conduit feed location. Attach conduit to integral power housing using ½" NPT conduit fitting (*provided by others*). Make sure power housing is level and flush to surface. Attach power housing to surface using #8 screws (*provided by others*). Feed line voltage wires through conduit and attach to quick-connect. Feed DMX control wires through the other conduit feed.

NOTE: Each back plate must be grounded. DMX and power wiring must be brought in through one of the end sections, **NOT** through any middle sections.

DO NOT POWER SYSTEM

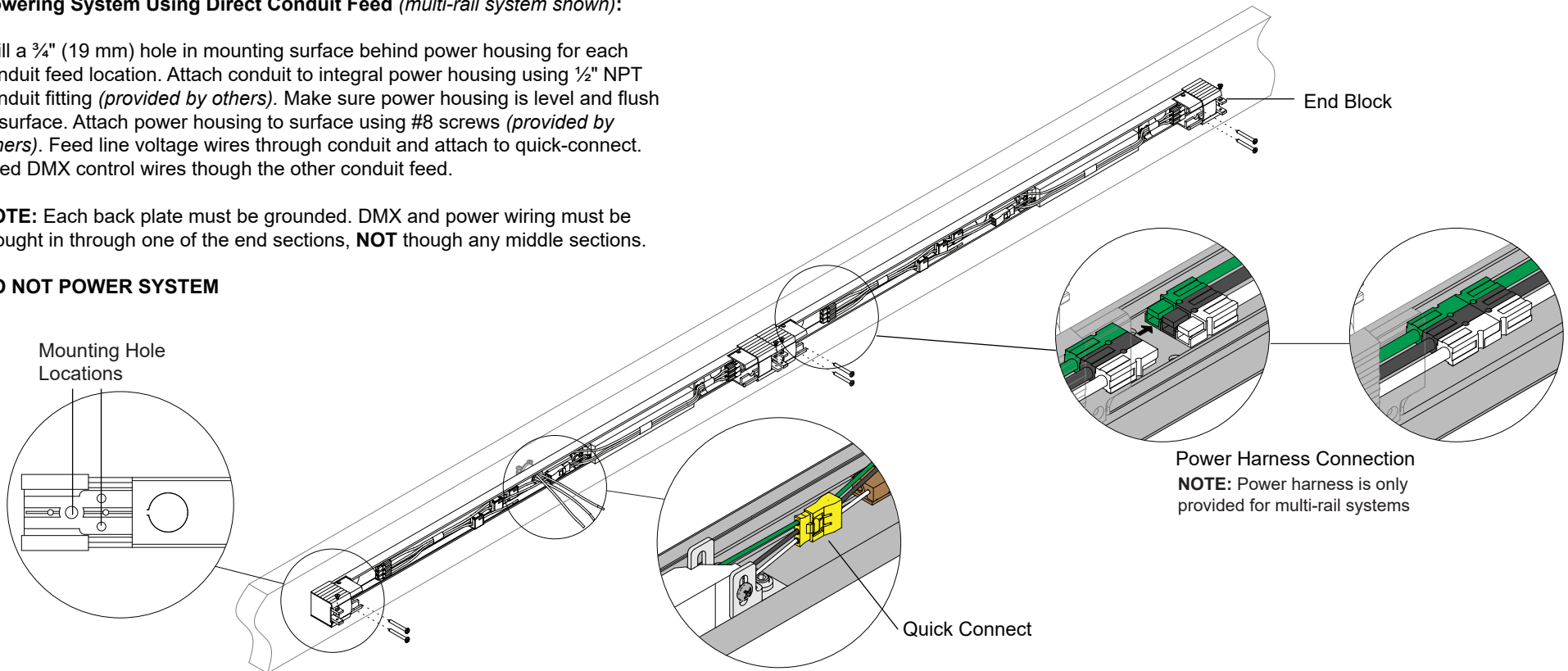

Installation Instructions

1 Mount Integral Power Housing and Make Line Voltage Connections cont'd

Powering System Through A Standard 4" J-Box (single rail system shown):

Install provided mounting plates to 4" J-Boxes (*provided by others*) using provided screws. Mounting plate has alignment markings to help proper installation. Make sure power housing is level and flush to surface. Attach power housing to surface using #8 screws (*provided by others*). Feed line voltage wires through knock-out hole and attach to quick-connect.

NOTE: Each back plate must be grounded. DMX power and dimming controls must be brought in through separate knock out holes, so 2 J-Box Covers are provided. DMX and power wiring must be brought in through one of the end sections, not through any middle sections.

DO NOT POWER SYSTEM

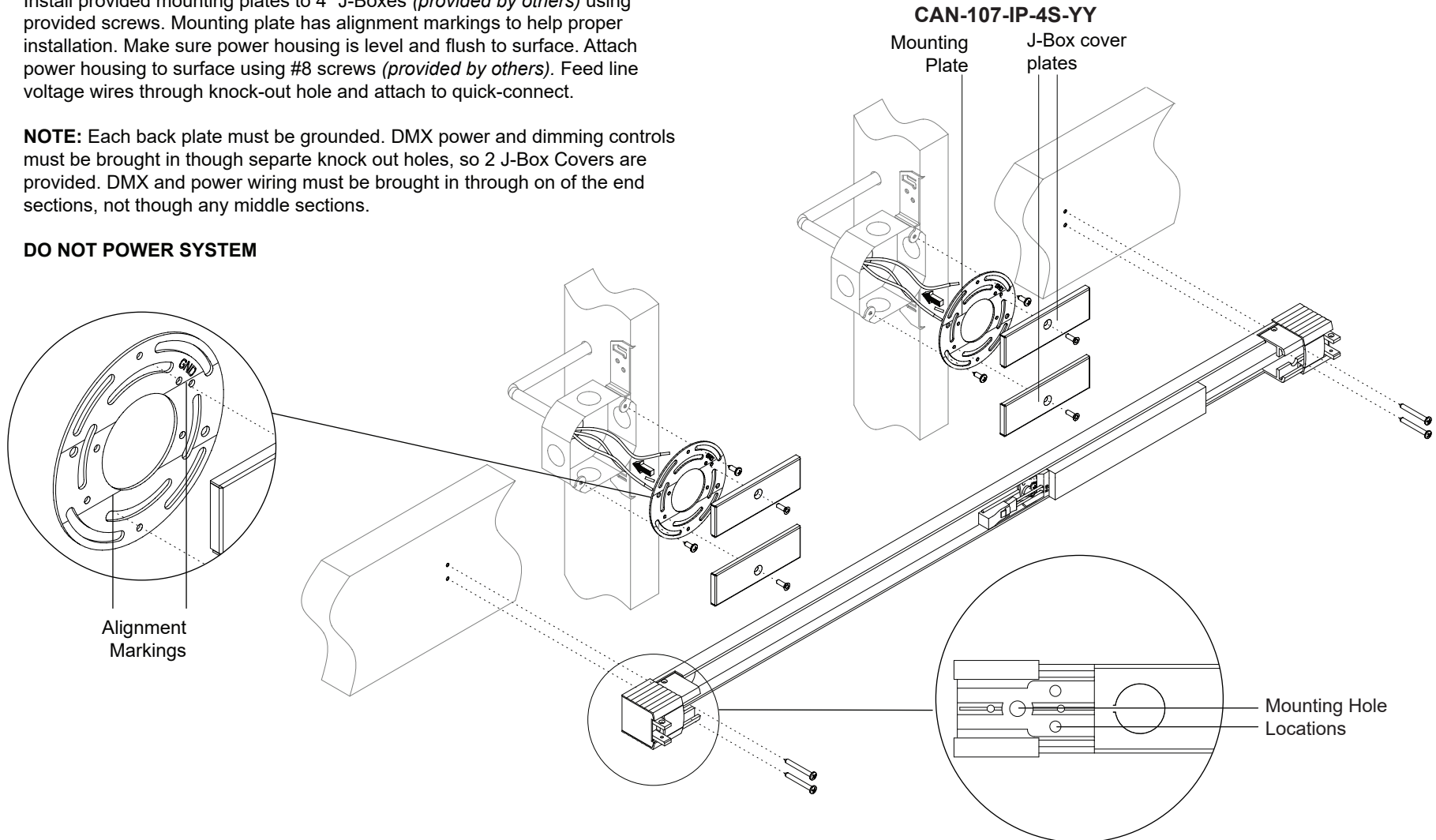

Installation Instructions

2 DMX Wire Connection

For Single-Rail systems: At the end of the wire opposite of the driver connection, install the provided RJ45 terminator to complete the circuit. Bring your control wires into the provided grey control wire at the end closest to the driver connection.

For Multi-Rail systems: Remove the pre-installed gray DMX control wire from the first driver housing, in the housing that control wires are installed into, carefully removing the Orange, Orange/White and Brown/White leads from the driver. Using the provided 6" jumper cable, install the Orange, Orange/White and Brown/White leads as shown below by compressing the terminal lock. Make power harness connections on all joint-sections using provided Gray power harness for DMX controls. Make sure mating connectors are completely secured to ensure that system will work properly. At the end of the last wire, install the provided RJ45 terminator to complete the circuit.

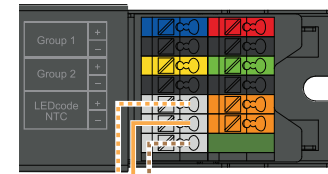

DMX in shield
DMX in -
DMX in +

AX | DMX, 100-0% dimming
eldoLED PW0561M (50w)

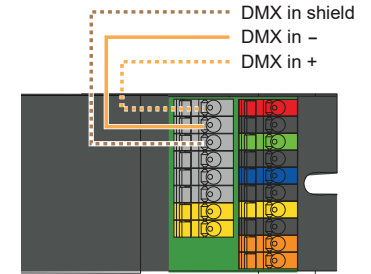

AX | DMX, 100-0% dimming
eldoLED PW1061M (100w)

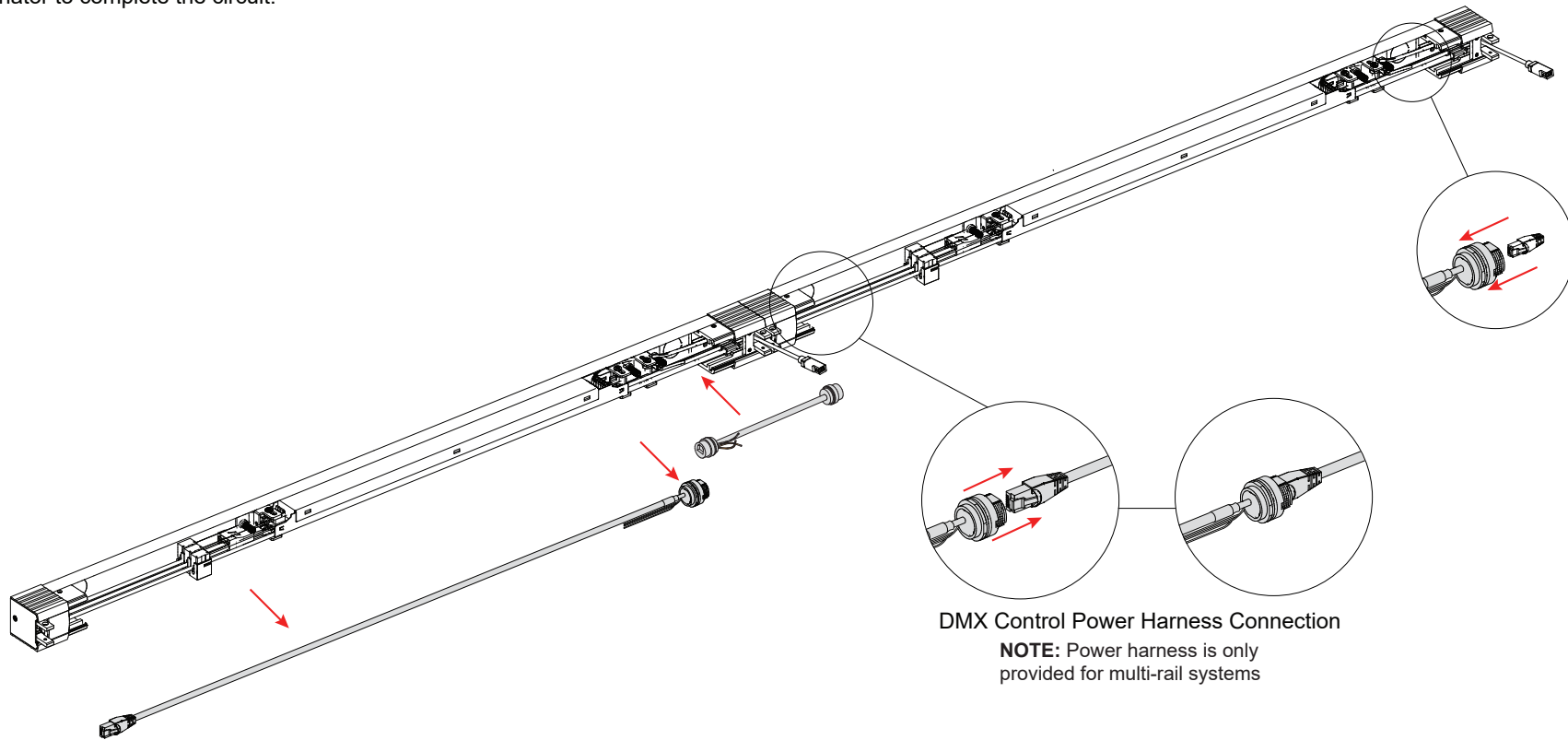

DMX Control Power Harness Connection

NOTE: Power harness is only provided for multi-rail systems

Installation Instructions

3 Arm and Wire Harness Installation

Arms should be installed with provided screws on the top of fixture for wall mount applications, or in the least visible position for ceiling mount applications.

For Single Rail Systems: Install single arms at the ends of system and secure with provided screws. Feed fixture power harness through arms on right side of each fixture. Leave 1" of loose wire.

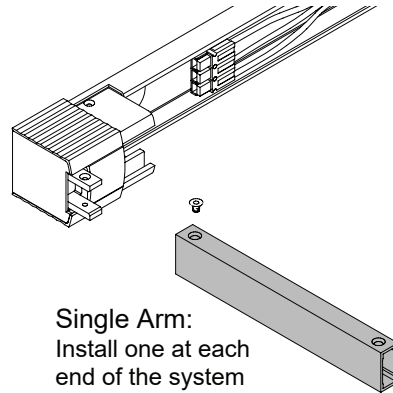

For Multi Rail Systems: Install single arms at ends of system and secure with provided screws. Double arms are installed where two integral power housings meet. Feed fixture power harness through arms on the right side of each fixture. Leave 1" of loose wire.

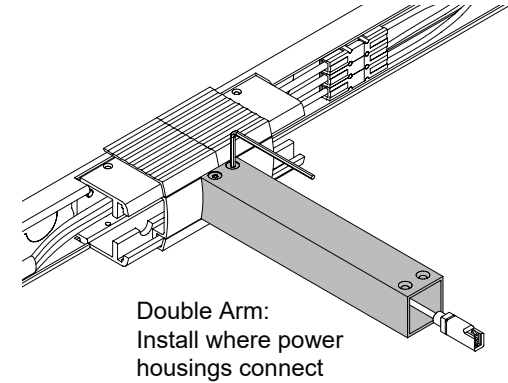

4 Rail installation

Connect rail wire harness to power harness using quick connects, as shown below. Be sure connectors are firmly fastened. Push excess wire into the arm(s), insert rail hub into the arm and secure in place using provided screws. Before securing rail, check that both hubs are aligned and rotates easily. **DO NOT FORCE.**

POWER SYSTEM ON.

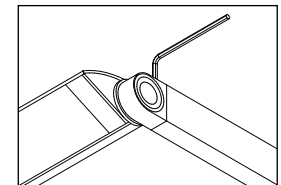
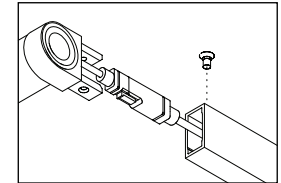
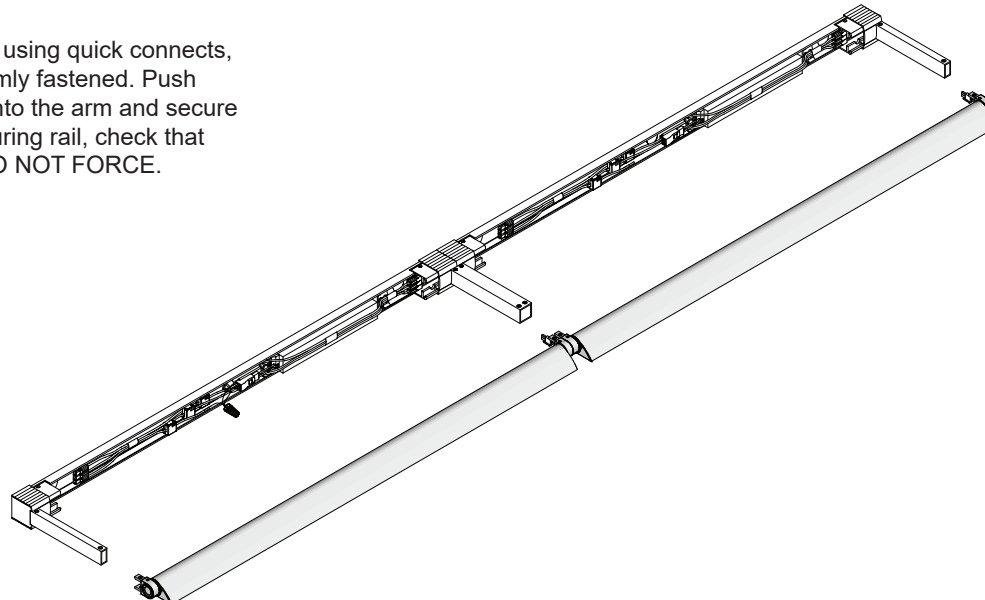

Rotate rail and secure in place.

Installation Instructions

5 Replacing Power Housing Cover

IMPORTANT: Before installing power housing cover, turn system **ON** and ensure system is fully operational.

Replace power housing cover and secure using provided screws, make sure all wires are inside the housing to protect them from pinching between back-plate and housing cover.

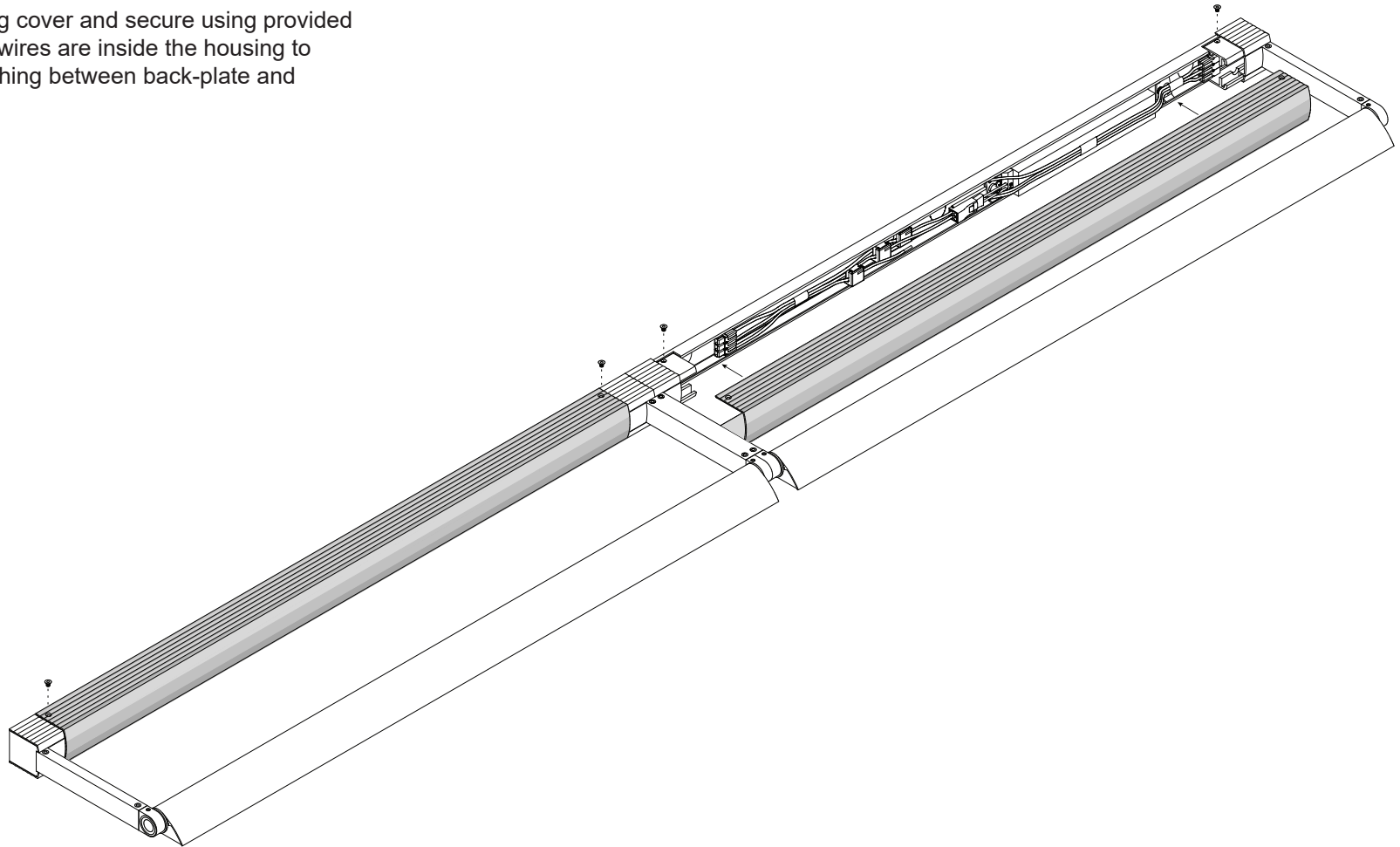

Appendix | Knock-Out Location

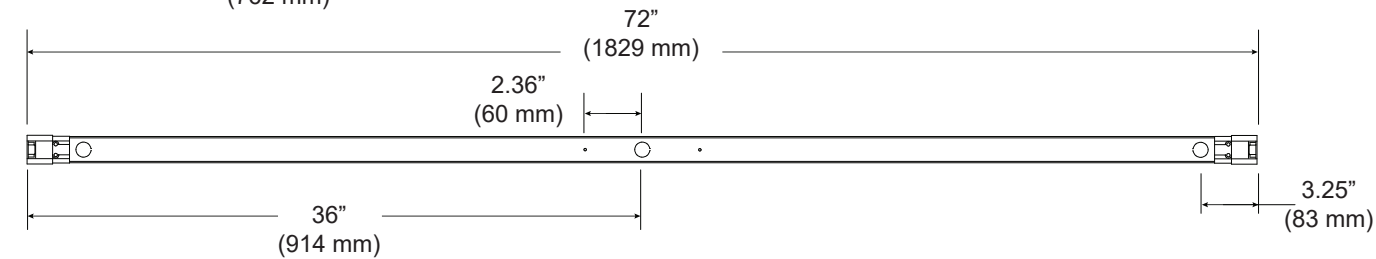
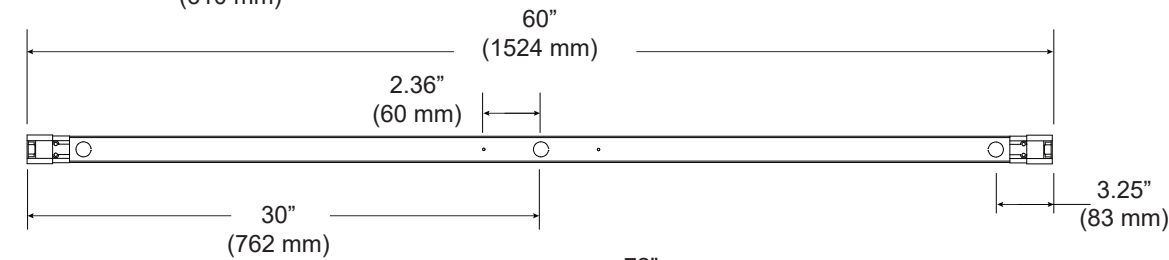
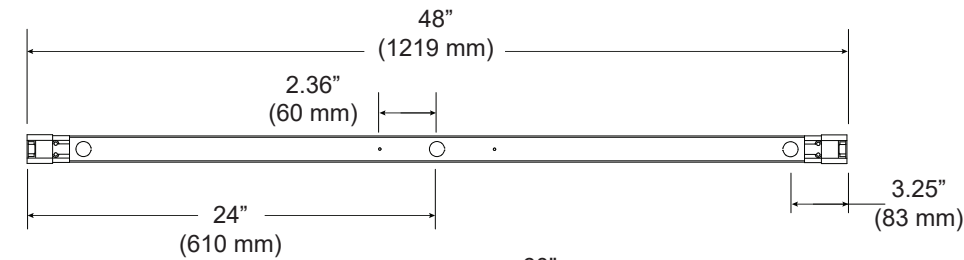
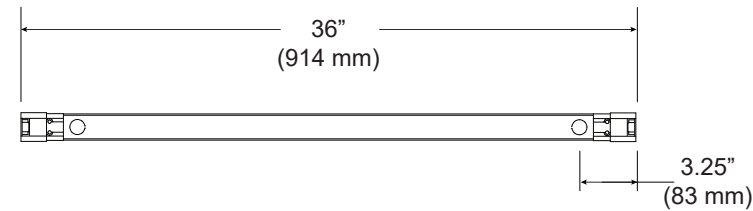
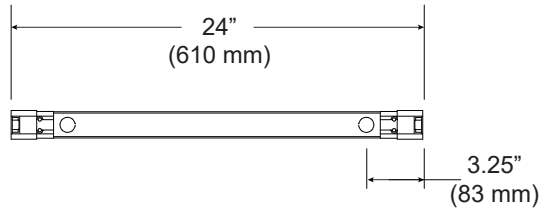

NOTE: Power always comes in the right side of the fixture. In single driver systems the driver is always installed on the right side with the screws facing away from the finished side.

NOTE: 48", 60" and 72" power housing have two extra mounting holes in the center

NOTE: For non-standard length housings, contact factory for customer specific installation guide with the number of knock-outs provided and their corresponding locations.

Appendix | Install Cable Tie-Back

Vode provides cable tie-back support for all Wall Mount systems with arms 18" and longer to prevent sag.

NOTE: Install cable tie-back support **AFTER** securing the rest of the system.

Step 1: Install Anchor

Carefully unscrew anchor from cable coupler. Using supplied screw, secure anchor to wall for all single and double arms. Cables should be installed at a 22.5° angle.

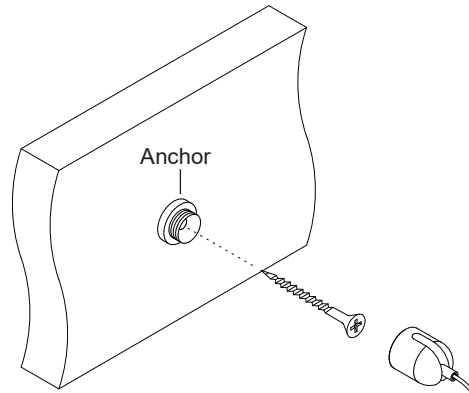

Step 2: Install Cable

Insert cable into arm keyhole.

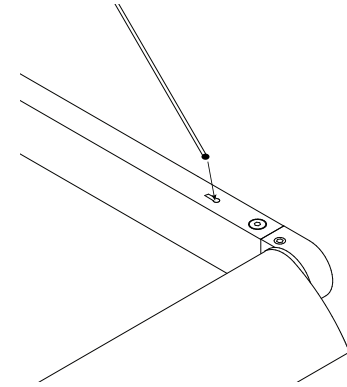

Step 3: Secure Cable(s)

Screw cable coupler to back plate.

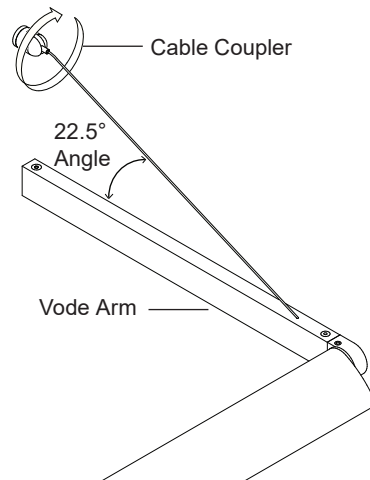

Step 4: Adjust System

Adjust cable using cord gripper to level system. Once level, cut excess cord, leaving at least 2 mm.

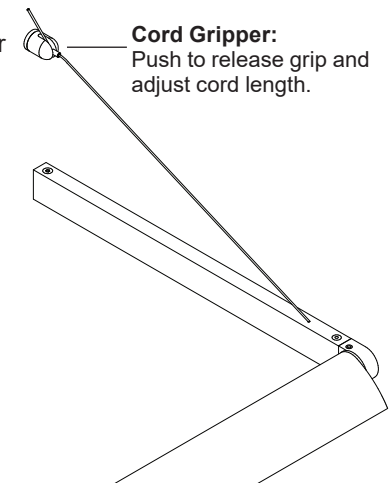

Appendix

Trouble Shooting Guide

Fixture will not turn on:

Check all wiring is correct and all connections are fastened properly.

If all wiring is correct, remove fixture and connect it to a known working driver. If the fixture lights up, then the problem is with the installed driver or wiring:

- 1) Check line voltage to driver is present.
- 2) Check driver wiring (see **Vode Driver Guide for details**) and check wiring to fixture.
- 3) Check driver and dimming system are compatible (see **Vode Dimmer Guide and the dimmer manufacturer's website**).

If fixture still doesn't light up, check all dimming wires are installed correctly. Reversed polarity at any point in the system will cause the entire system to not work, (see **Vode Driver Guide for wiring details**).

Fixture is not dimming properly:

Check all wiring is correct and all connections are fastened properly.

Check driver wiring (see **Vode Driver Guide for details**). Make sure driver is compatible with dimming controls (see **Vode Dimmer Guide and the dimmer manufacturer's website**).

Rail is not rotating:

DO NOT FORCE RAIL! When properly installed, rails will turn easily.

Check that both hub set screws are loose. If rail will still not turn, uninstall rail from arms, paying attention to the wire harness connection. Check that both hubs and arm tabs are rotated in the same direction.

For any help with operation or technical information, contact Vode Tech Service at 707-996-9898 or technicalsupport@vode.com.

Important Notes

- Listed to UL standards for damp location by a Nationally Recognized Testing Laboratory (NRTL) recognized by OSHA
- Operating Temperature: 32°F to 104°F (0°C to 40°C).
- Input Voltage: 120v - 277v, 50/60hz.
- Power Type: Class 2 (<60v) constant current driver.
- Dimming curve is factory preset to linear. Logarithmic is available upon request. See Vode Driver Guide for specific details and wiring diagram.
- Unless specified, one driver per rail will be supplied.
- 5 Year Limited Warranty. All material and component parts manufactured by Vode are guaranteed to be free from defects of material and/or workmanship for a period of 5 years from date of sale. Product must be installed according to Vode installation instructions and accepted trade practices. Power supplies and other auxiliary equipment are not covered under Vode warranty but may be covered by separate OEM warranty.