



Spec Guide

BoxRail | Ceiling-Wall Arm | 107



Direct or indirect lighting for open office, wall wash and ambient applications.



BoxRail: direct or indirect, 370° rotation.

Benefits & Features

Minimal Profile, Robust Design

Square profile, 1.14" (29mm) x 1.14" (29mm).

Superior Light Quality & Performance

Output up to 1484 lm/ft (4869 lm/m) (HO), 131 lm/W (SO). 80 or 90 CRI & tunable white (2200K-5000K) available.

Adaptive Power

Full range dimming power for all protocols. Integral or remote power available.

Better Optics & Beam Control Options

Batwing, FlyWing, MicroBaffle, diffuse lens and narrow optics available. Directional control with 370° rotation, angle gauge and lock.

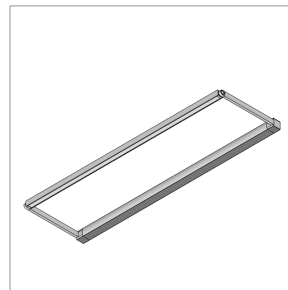

Integral Driver Housing

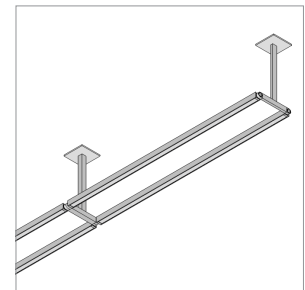

Double Rail with Tee, Square Canopy, Continuous System

Build Your Specification

107-BX					
System & Rail Type	Single/Double Rail	System Length	Rail Length	Mounting	Arm Length
107-BX BoxRail	01 Single Rail 03 Double Rail with 3" (76mm) Tee 06 Double Rail with 6" (152mm) Tee 12 Double Rail with 12" (305mm) Tee ZZ Other (please specify)	Specify overall system length in ft/in or M/mm. <i>Corner and Shapes Available</i> See Guide for details.	24 24" (610mm) 36 36" (914mm) 48 48" (1219mm) 60 60" (1524mm) 72 72" (1829mm) ZZ Other rail length or layout (please specify)	CA Ceiling Arm WA Wall Arm	1.25 1.25" arm (32mm) ¹ 3 3" arm (76mm) 6 6" arm (152mm) 12 12" arm (305mm) 18 18" arm (457mm) ² 24 24" arm (610mm) ² ZZ Other (please specify)
See Rail Length Chart for more details. ⚠ Custom lengths may result in light gaps on the fixture. See Rail Length Chart for more details.					

>>		
Power Location	Power Type	Voltage
Integral Power	Flexible 1 to 1 Power	1 120V
IP Integral Power	AE 0-10v, 1.0% Dimming	2 120V - 277V
Remote Power	AT 0-10v, 0.1% Dimming	X Not Yet Specified
Specify mounting and harness length code example: 2R25 , 4R25 ...etc.	AD DALI, 0.1% Dimming	
Mounting Option	AX DMX, 100-0% Dimming	
Wire Harness	AH Hi-lume 1% EcoSystem, Soft On / Fade to Black Technology, LDE ¹	
00 Zero Canopy	AH2 ELV 1% 2-wire (Forward and Reverse Phase)	
0B Zero Block		
2R Small Round Canopy	Optimized Power	
2S Small Square Canopy	Add 'O' to power type	
4R Large Round Canopy	example: AEO, ATO...etc. ³	
4S Large Square Canopy	VodeNODE	
	Add 'N' to power type for Flexible 1 to 1 Power	
	Add 'ON' to power type for Optimized Power	
	example: AEN, ATN, AEON, ADON...etc. ⁴	
	ZZ Other (please specify)	
	See Power Guide for driver features & limitations.	

>>					
Emergency Power	LED Type	Lumen Output	Color Temperature	Optics	Sensors
0 No Emergency Power	Z Zipper Board	LO Low Output	80+ CRI	Zipper Board (Z)	0 None
ZZ Emergency Power (specify requirements)	B Button Board ⁵	SO Standard Output	27 2700K	1 Diffuse	ZZ Sensor (specify requirements)
		HO High Output	30 3000K	WB White Baffle	
		ZZ Other (please specify)	35 3500K	BB Black Baffle	
		See IES Files page for details.	40 4000K	G1 120° Batwing	
		See Power Guide for driver features & limitations.	90+ CRI	G2 120° FlyWing	
			279 2700K	S1 40° Symmetric	
			309 3000K	S2 60° Symmetric	
			359 3500K	A1 85° Asymmetric	
			409 4000K	Button Board (B)	
			ZZ Tunable White Available	19 19° x 48° Oval	
			See Guide for details.	36 36° Medium	

>>	
Finish	Options
AL Clear Anodized	0 None
WH White Powder Coat	9 9' 18/3 Cord and Plug ⁶
BL Black Anodized	CP Chicago Plenum ⁷
ZZ Other (please specify)	

NOTES & LIMITATIONS

- ¹ 1.25" arm length is not available with Zero Block (0B) mount.
- ² For arms 18" and longer, wall-mounted systems include a cable tie-back.
- ³ Optimized Power is not available with Hi-lume 1% EcoSystem (AHO) Power Type.
- ⁴ VodeNODE enclosure is not available with ELV 1% 2-wire (AH2) Power Type.
- ⁵ Button Board (B) optics are not available with Low Output (LO) or 90 CRI.
- ⁶ 9' 18/3 Cord and Plug only available with Remote Power (RP).
- ⁷ Chicago Plenum not applicable for wall arm mounting.

Standard 5 Year Limited Warranty. See details [here](#). Contact factory for options on Limited Warranties up to 20 years.

Listed to UL standards for damp location by a Nationally Recognized Testing Laboratory (NRTL) recognized by OSHA. Certain limitations exist for each Certification. Contact factory for verification.



Applications

General Interior and Open Office



Barclays Global Investors Office, San Francisco, CA

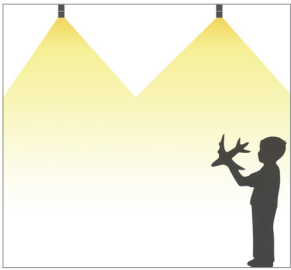

Special Use Office Building

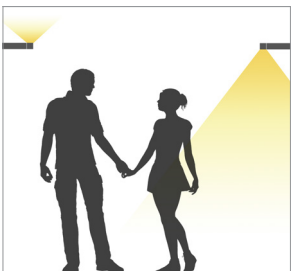

Harley-Davidson Museum, Milwaukee, WI

Declare Label

All Vode Lighting linear light fixtures proudly carry the Red List Approved designation.

See [International Living Future Institute](https://www.living-future.org) website for details.



Vode Adaptive Architectural Lighting Systems
Vode Lighting LLC

Final Assembly: Sonoma, California, US
Life Expectancy: 10+ Year(s)
End of Life Options: Recyclable (100%)

Ingredients:

Anodized Aluminum (6063-T5 Alloy); Steel; Small Electrical Component (RoHS)¹; Copper; **Fluorinated Ethylene Propylene (masterbatch)**²; Polymethyl methacrylate (PMMA); Stainless Steel; Polyoxymethylene Copolymer (POM); Styrene-butadiene polymer, hydrogenated; Poly(methyl methacrylate/butyl acrylate/styrene) (PMMA/BA/S); Styrene/butadiene copolymer; Distillates; Polypropylene; Calcium carbonate; Polycarbonate; EVA Copolymer; Methyl methacrylate (MMA); Polyphenylene Oxide; Brass; Tin, Organic

¹LBC Temp Exception RL-002 - Small Electrical Components
²LBC Temp Exception RL-023 - Wire Sheathing Subject to NFPA 90A, NFPA 262, UL® 910

Living Building Challenge Criteria: Compliant

I-13 Red List:

<input type="checkbox"/> LBC Red List Free	% Disclosed: 100% at 100ppm
<input checked="" type="checkbox"/> LBC Red List Approved	VOC Content: Not Applicable
<input type="checkbox"/> Declared	

I-10 Interior Performance: Not Applicable
I-14 Responsible Sourcing: Not Applicable

VDE-0001
 EXP. 01 JAN 2025
 Original Issue Date: 2018

MANUFACTURER RESPONSIBLE FOR LABEL ACCURACY
 INTERNATIONAL LIVING FUTURE INSTITUTE™ [living-future.org/declare](https://www.living-future.org/declare)



Structure

Rail Lengths	24" (610mm) - 72" (1829mm). Modified lengths available. See Rail Length Chart for more details.
Rail Dimensions	1.14" (29mm) x 1.14" (29mm) x length.
Construction	Extruded and machined 6063 aluminum.
Mounting	Ceiling or wall mount to jbox or driver housing.
Arm Length	1.25" (32mm) - 24" (610mm). Non-standard arm lengths available.
System Run Length	24" (610mm) minimum. Unlimited maximum.
Operating Temperature	32°F to 104°F (0°C to 40°C).
Humidity	0-85%, non-condensing.
System Weight	1.04 lbs per ft (0.47kg per 305mm) Power supply and housing not included.

Materials

LED Board Construction	Aluminum core PCB, black LCP connectors, RoHS compliant.
Lens	High-impact extruded acrylic glass (PMMA).
Baffle	6063 Aluminum, RoHS compliant painted finish.
Button Optics	High-impact cast acrylic glass (PMMA), polycarbonate (PC) holder.
Power Cable	Ø4mm, 18/2 AWG, Plenum (CMP) rated semi-rigid PVC or FEP, flame tested UL-910 (PVC free in 2020).
Cable Connectors	Unfilled black nylon, rated UL 94 V-0, halogen free, PVC or FEP overmold, RoHS compliant (PVC free in 2020).
Remote Linear Power Housing (RLP)	20.7" x 2.375" x 2.53", 0.054" formed Galvanized Steel.
Remote Brick Power Housing (RBP)	4.32" x 3.37" x .078" Galvanized Steel mounting plate.

Dimensions

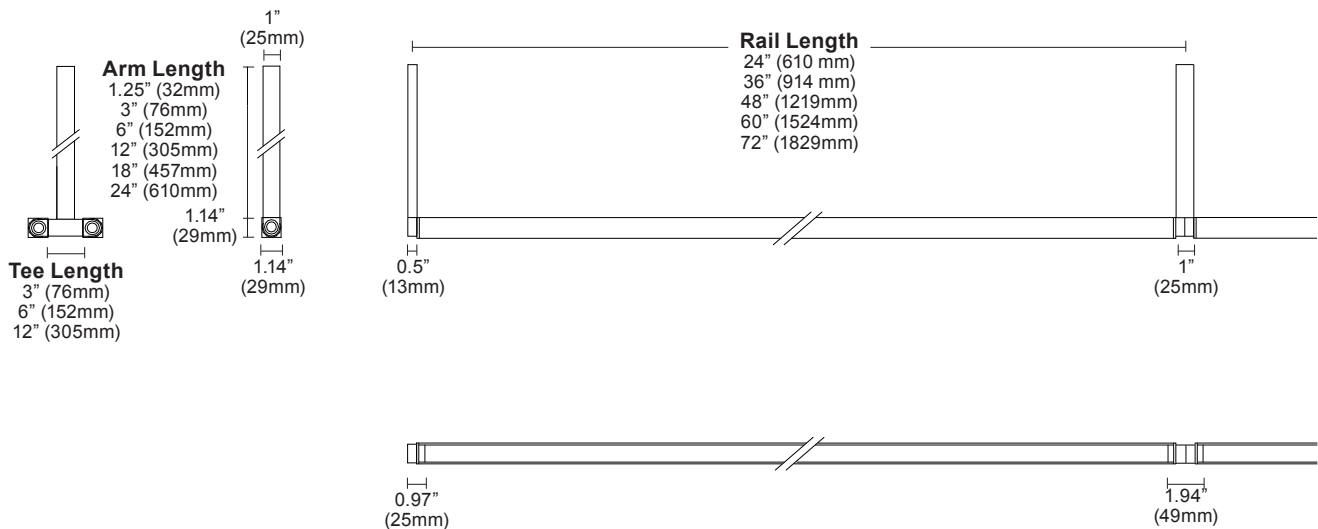

Mounting Options

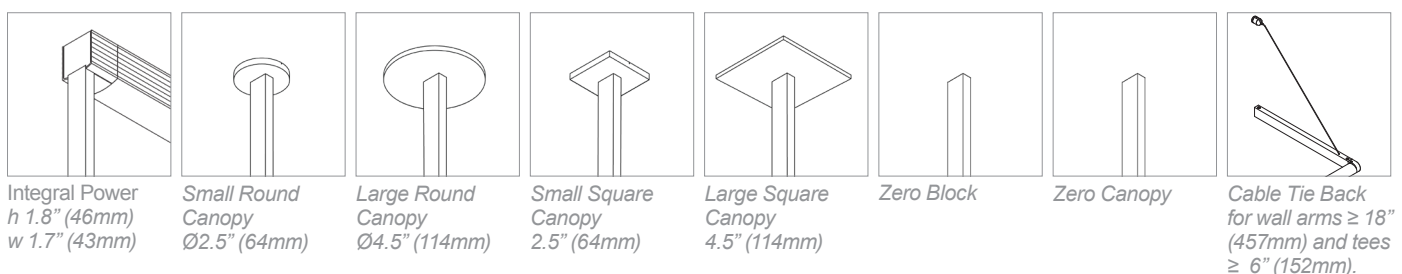

Layout

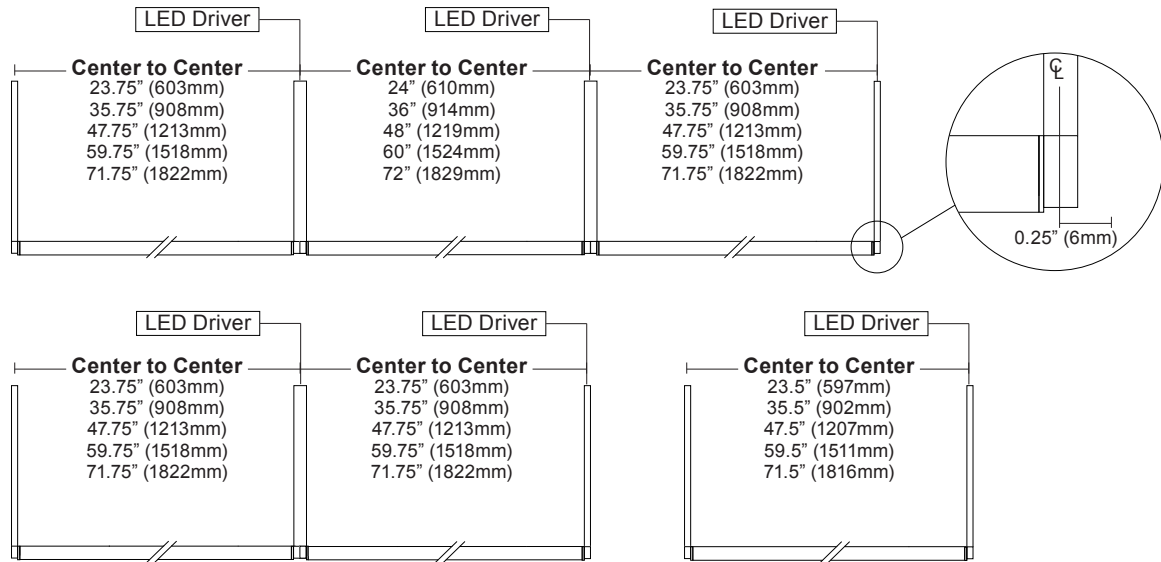

Corner and Shapes Available (Square, Rectangle, L-Shape, U-Shape, ZigZag) [See Guide](#) for details.

Power and Controls

Power Type	Class 2 (<60V output) constant current driver.
Dimming Controls	Dimming (0.1%, 1%), 0-10V, DALI, DMX, Hi-lume 1% are available. See Power Guide for details.
Input Voltage	120V - 277V, 50/60hz.
Power Location	Integral or remote power. Maximum remote distance up to 100' (30.5m) depending on driver selection. See Power Guide for details.

Vode power locations fall into two categories: integral and remote. Remote power is locating the power supply away from the fixture. Remote power comes in two housing styles: brick style and linear style. Consult [Power Guide](#) to determine which type you will receive. Integral power is locating the power supply into the lighting fixture or mounting.

Remote Brick Power Housing

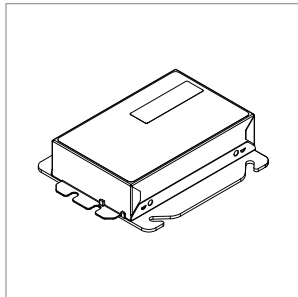

Supplied for some remote power applications. One remote power supply housing is supplied for each rail. Provided driver mounting plate fits standard 4" metal, square J-Boxes with a minimum volume of 21 in³ (J-Box not provided). See [Tech Sheet](#) for details.

Remote Linear Power Housing

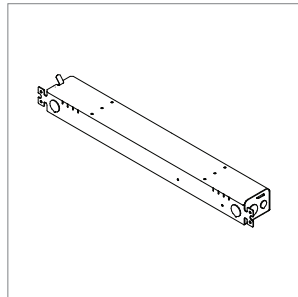

One remote power supply housing is supplied with each power supply. All Vode linear remote drivers come in a 0.054" (0.8mm) formed galvanized steel power supply housing with five (5) knockouts: (4) 1-1/8", (1) 7/8" and (1) 9/16". Accommodates standard linear power supplies. See [Tech Sheet](#) for details.

Integral Power

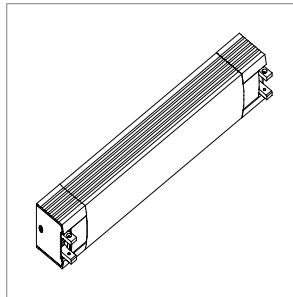

Houses integral power supply. Direct conduit feed recommended. Housing mounts to standard North America 4" j-box. Blocking recommended at all arm junctions. See [Tech Sheet](#) for details.

Wire Harness

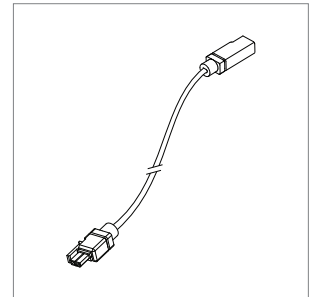

Wire harness connects driver to rail section. Lengths of 10' (3.0m) & 25' (7.6m) with snap-lock connectors for quick and easy installation. Multiple harnesses may be combined for lengths up to 100' (30.5m). See [Tech Sheet](#) for details.

Power and Controls

Flexible 1 to 1 power

For Flexible 1 to 1 Power, Vode supplies one single output driver per fixture, allowing each fixture to be controlled independently. Direct/Indirect fixtures are supplied with two single output drivers, allowing the direct and indirect lighting to be controlled independently. Consult [Power Guide](#) to determine which type you will receive.

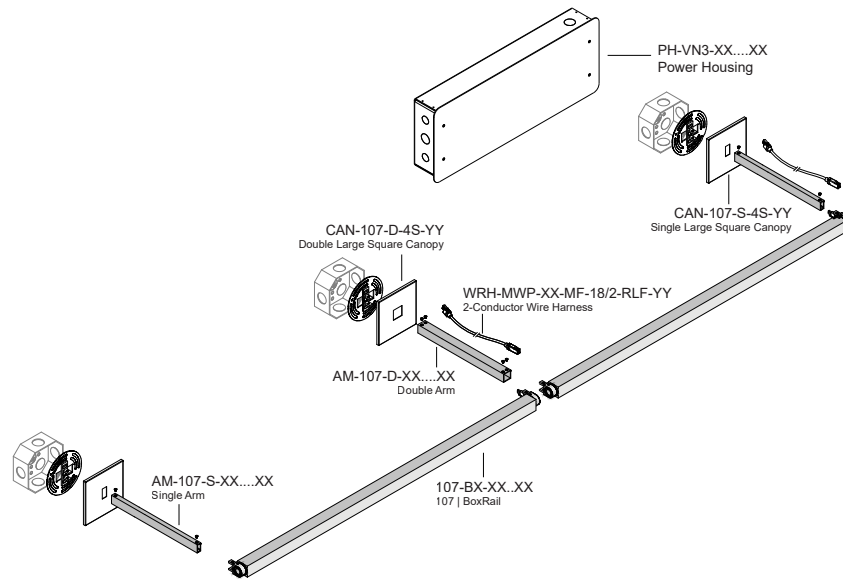

Optimized Power

To optimize power, Vode configures specifications with drivers that have 2 or 4 outputs. Depending on system configurations and power requirements, up to 4 fixtures can be powered from a 4-output driver. Consult [Power Guide](#) to determine which type you will receive.

IMPORTANT: Each fixture will still require individual wire harnesses, as shown below.

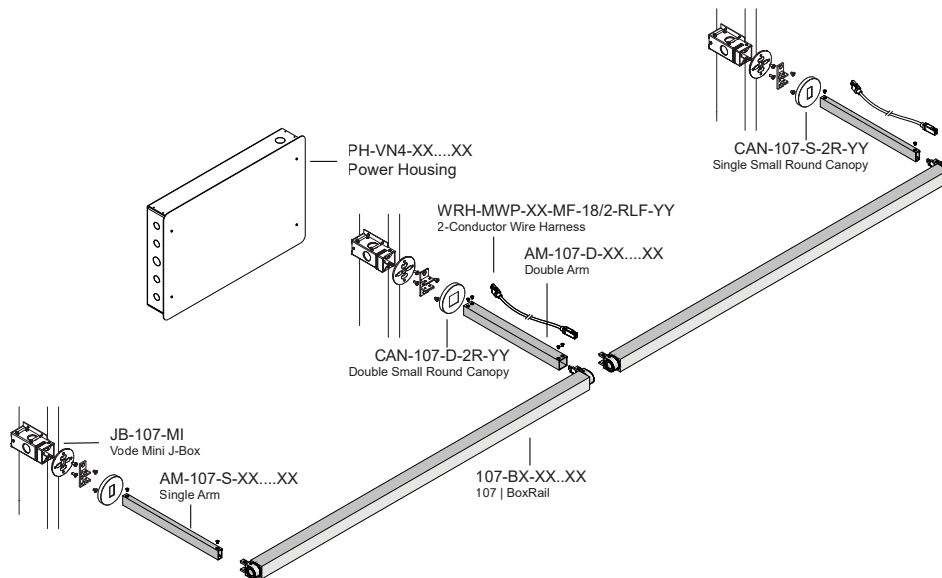

Note: Drawings not to scale, for reference only.

Performance | Zipper Board Optics

Zipper Board Optics design has 72 diodes per foot (305mm).

Diffuse (1)

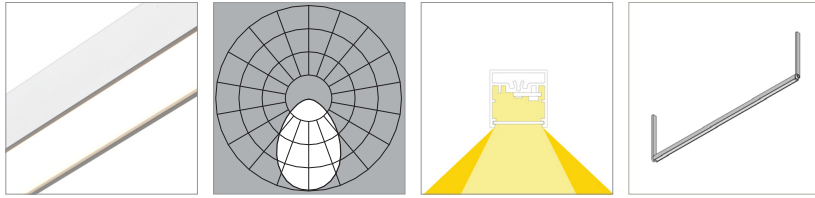

L80 >60,000 hours

	80 CRI (80min., 84 avg.)				90 CRI (90min., 96 avg.)			
	2700K	3000K	3500K	4000K	2700K	3000K	3500K	4000K
Low Output (LO)								
Efficacy - Lumens per Watt	93	96	98	98	81	83	85	86
Lumens per foot (305mm)	321	331	338	338	277	286	292	294
Watts per foot (305mm)	3.5	3.5	3.5	3.5	3.5	3.5	3.5	3.5

Standard Output (SO)								
Efficacy - Lumens per Watt	108	111	114	114	93	96	98	99
Lumens per foot (305mm)	642	663	676	676	554	571	583	589
Watts per foot (305mm)	6.0	6.0	6.0	6.0	6.0	6.0	6.0	6.0

High Output (HO)								
Efficacy - Lumens per Watt	100	103	105	105	86	89	91	92
Lumens per foot (305mm)	1221	1259	1285	1285	1052	1086	1108	1119
Watts per foot (305mm)	12.3	12.3	12.3	12.3	12.3	12.3	12.3	12.3

White Baffle (WB)

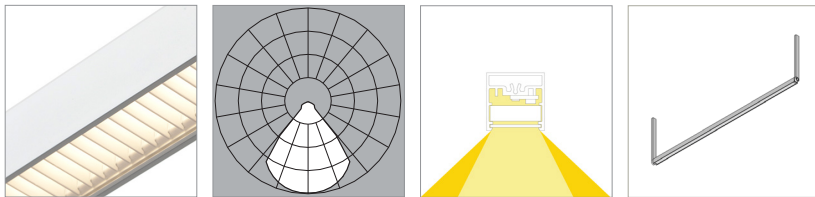

L80 >60,000 hours

	80 CRI (80min., 84 avg.)				90 CRI (90min., 96 avg.)			
	2700K	3000K	3500K	4000K	2700K	3000K	3500K	4000K
Low Output (LO)								
Efficacy - Lumens per Watt	65	67	69	69	56	58	59	60
Lumens per foot (305mm)	223	230	235	235	192	199	203	205
Watts per foot (305mm)	3.5	3.5	3.5	3.5	3.5	3.5	3.5	3.5

Standard Output (SO)								
Efficacy - Lumens per Watt	75	78	79	79	65	67	68	69
Lumens per foot (305mm)	447	461	470	470	385	397	405	409
Watts per foot (305mm)	6.0	6.0	6.0	6.0	6.0	6.0	6.0	6.0

High Output (HO)								
Efficacy - Lumens per Watt	44	45	46	46	60	62	63	64
Lumens per foot (305mm)	531	548	559	559	731	755	770	778
Watts per foot (305mm)	12.3	12.3	12.3	12.3	12.3	12.3	12.3	12.3

Performance | Zipper Board Optics

Zipper Board Optics design has 72 diodes per foot (305mm).

Black Baffle (BB)

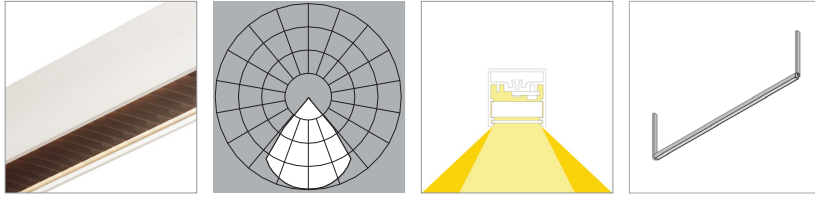

L80 >60,000 hours

	80 CRI (80min., 84 avg.)				90 CRI (90min., 96 avg.)			
	2700K	3000K	3500K	4000K	2700K	3000K	3500K	4000K
Low Output (LO)								
Efficacy - Lumens per Watt	35	36	37	37	31	31	32	32
Lumens per foot (305mm)	120	124	127	127	104	107	109	110
Watts per foot (305mm)	3.5	3.5	3.5	3.5	3.5	3.5	3.5	3.5

Standard Output (SO)

Efficacy - Lumens per Watt	41	42	43	43	35	36	37	37
Lumens per foot (305mm)	241	248	253	253	207	214	218	220
Watts per foot (305mm)	6.0	6.0	6.0	6.0	6.1	6.1	6.1	6.1

High Output (HO)

Efficacy - Lumens per Watt	38	39	40	40	33	34	34	35
Lumens per foot (305mm)	457	471	481	481	394	406	415	419
Watts per foot (305mm)	12.3	12.3	12.3	12.3	12.3	12.3	12.3	12.3

120° Batwing (G1)

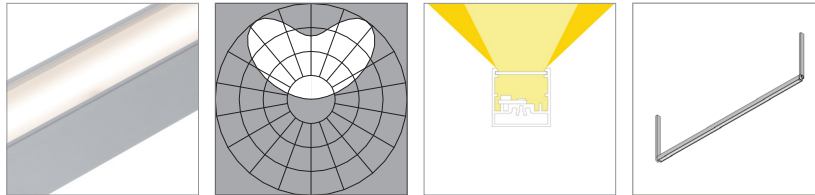

L80 >60,000 hours

	80 CRI (80min., 84 avg.)				90 CRI (90min., 96 avg.)			
	2700K	3000K	3500K	4000K	2700K	3000K	3500K	4000K
Low Output (LO)								
Efficacy - Lumens per Watt	109	112	114	114	94	97	99	100
Lumens per foot (305mm)	373	385	393	393	323	333	340	344
Watts per foot (305mm)	3.5	3.5	3.5	3.5	3.5	3.5	3.5	3.5

Standard Output (SO)

Efficacy - Lumens per Watt	125	129	132	132	108	111	114	115
Lumens per foot (305mm)	746	770	786	786	641	662	675	682
Watts per foot (305mm)	6.0	6.0	6.0	6.0	6.0	6.0	6.0	6.0

High Output (HO)

Efficacy - Lumens per Watt	116	120	122	122	100	104	106	107
Lumens per foot (305mm)	1418	1463	1493	1493	1226	1265	1291	1303
Watts per foot (305mm)	12.3	12.3	12.3	12.3	12.3	12.3	12.3	12.3

Performance | Zipper Board Optics

Zipper Board Optics design has 72 diodes per foot (305mm).

120° FlyWing (G2)

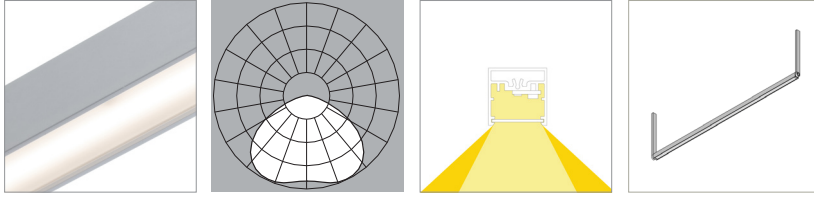

L80 >60,000 hours

80 CRI (80min., 84 avg.)

90 CRI (90min., 96 avg.)

Low Output (LO)

	2700K	3000K	3500K	4000K	2700K	3000K	3500K	4000K
Efficacy - Lumens per Watt	111	114	116	116	95	98	100	101
Lumens per foot (305mm)	380	392	400	400	328	338	345	349
Watts per foot (305mm)	3.5	3.5	3.5	3.5	3.5	3.5	3.5	3.5

Standard Output (SO)

Efficacy - Lumens per Watt	128	132	135	135	110	114	116	117
Lumens per foot (305mm)	761	785	801	801	656	676	690	697
Watts per foot (305mm)	6.0	6.0	6.0	6.0	6.0	6.0	6.0	6.0

High Output (HO)

Efficacy - Lumens per Watt	118	122	125	125	102	105	107	108
Lumens per foot (305mm)	1445	1491	1521	1521	1246	1285	1311	1325
Watts per foot (305mm)	12.3	12.3	12.3	12.3	12.3	12.3	12.3	12.3

40° Symmetric (S1)

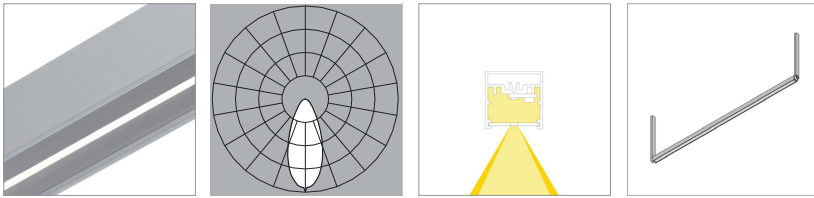

L80 >60,000 hours

80 CRI (80min., 84 avg.)

90 CRI (90min., 96 avg.)

Low Output (LO)

	2700K	3000K	3500K	4000K	2700K	3000K	3500K	4000K
Efficacy - Lumens per Watt	46	48	49	49	40	41	42	42
Lumens per foot (305mm)	158	163	166	166	136	140	143	145
Watts per foot (305mm)	3.5	3.5	3.5	3.5	3.5	3.5	3.5	3.5

Standard Output (SO)

Efficacy - Lumens per Watt	53	55	56	56	46	47	48	49
Lumens per foot (305mm)	315	325	332	332	272	281	286	289
Watts per foot (305mm)	6.0	6.0	6.0	6.0	6.0	6.0	6.0	6.0

High Output (HO)

Efficacy - Lumens per Watt	49	51	52	52	43	44	45	45
Lumens per foot (305mm)	599	618	631	631	517	533	544	549
Watts per foot (305mm)	12.3	12.3	12.3	12.3	12.3	12.3	12.3	12.3

Performance | Zipper Board Optics

Zipper Board Optics design has 72 diodes per foot (305mm).

60° Symmetric (S2)

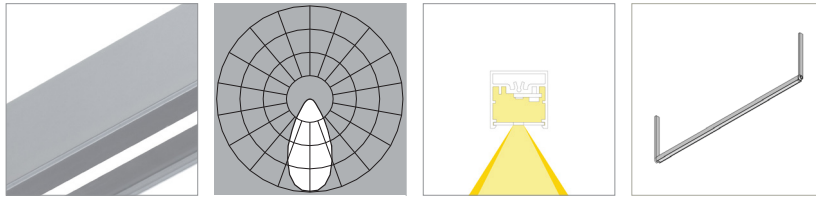

L80 >60,000 hours

Low Output (LO)	80 CRI (80min., 84 avg.)				90 CRI (90min., 96 avg.)			
	2700K	3000K	3500K	4000K	2700K	3000K	3500K	4000K
Efficacy - Lumens per Watt	62	64	65	65	54	55	56	57
Lumens per foot (305mm)	213	220	224	224	183	189	193	195
Watts per foot (305mm)	3.5	3.5	3.5	3.5	3.5	3.5	3.5	3.5

Standard Output (SO)

Efficacy - Lumens per Watt	72	74	75	75	62	64	65	66
Lumens per foot (305mm)	426	439	448	448	367	379	386	390
Watts per foot (305mm)	6.0	6.0	6.0	6.0	6.0	6.0	6.0	6.0

High Output (HO)

Efficacy - Lumens per Watt	66	69	70	70	57	59	60	61
Lumens per foot (305mm)	809	834	851	851	697	719	734	741
Watts per foot (305mm)	12.3	12.3	12.3	12.3	12.3	12.3	12.3	12.3

85° Asymmetric (A1)

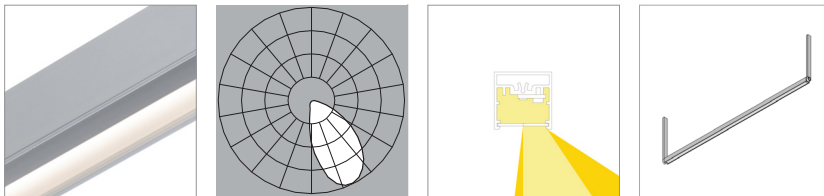

L80 >60,000 hours

Low Output (LO)	80 CRI (80min., 84 avg.)				90 CRI (90min., 96 avg.)			
	2700K	3000K	3500K	4000K	2700K	3000K	3500K	4000K
Efficacy - Lumens per Watt	63	65	67	67	55	56	58	58
Lumens per foot (305mm)	217	224	229	229	187	193	197	199
Watts per foot (305mm)	3.5	3.5	3.5	3.5	3.5	3.5	3.5	3.5

Standard Output (SO)

Efficacy - Lumens per Watt	73	76	77	77	63	65	67	67
Lumens per foot (305mm)	435	448	458	458	375	387	395	398
Watts per foot (305mm)	6.0	6.0	6.0	6.0	6.0	6.0	6.0	6.0
CRI								

High Output (HO)

Efficacy - Lumens per Watt	68	70	71	71	59	60	62	62
Lumens per foot (305mm)	826	852	869	869	712	735	750	757
Watts per foot (305mm)	12.3	12.3	12.3	12.3	12.3	12.3	12.3	12.3

Performance | Zipper Board Optics

Zipper Board Optics design has 72 diodes per foot (305mm).

40° Symmetric, black finish (S1-BL)

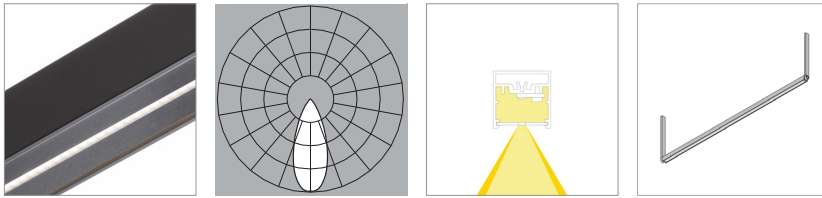

L80 >60,000 hours

Low Output (LO)	80 CRI (80min., 84 avg.)				90 CRI (90min., 96 avg.)			
	2700K	3000K	3500K	4000K	2700K	3000K	3500K	4000K
Efficacy - Lumens per Watt	34	35	35	35	29	30	31	31
Lumens per foot (305mm)	114	118	120	120	99	102	104	105
Watts per foot (305mm)	3.5	3.5	3.5	3.5	3.5	3.5	3.5	3.5

Standard Output (SO)

Efficacy - Lumens per Watt	39	40	41	41	34	35	35	36
Lumens per foot (305mm)	229	236	241	241	197	204	208	210
Watts per foot (305mm)	6.0	6.0	6.0	6.0	6.0	6.0	6.0	6.0

High Output (HO)

Efficacy - Lumens per Watt	36	37	38	38	31	32	33	33
Lumens per foot (305mm)	435	449	458	458	375	387	395	399
Watts per foot (305mm)	12.3	12.3	12.3	12.3	12.3	12.3	12.3	12.3

60° Symmetric, black finish (S2-BL)

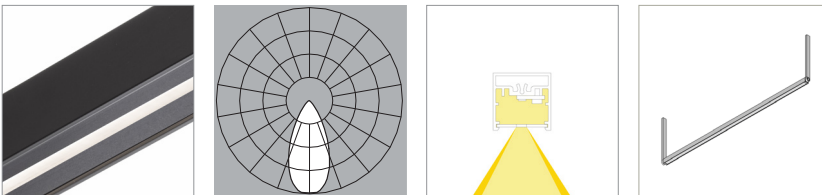

L80 >60,000 hours

Low Output (LO)	80 CRI (80min., 84 avg.)				90 CRI (90min., 96 avg.)			
	2700K	3000K	3500K	4000K	2700K	3000K	3500K	4000K
Efficacy - Lumens per Watt	39	40	41	41	34	35	35	36
Lumens per foot (305mm)	133	137	140	140	115	118	121	122
Watts per foot (305mm)	3.5	3.5	3.5	3.5	3.5	3.5	3.5	3.5

Standard Output (SO)

Efficacy - Lumens per Watt	45	46	47	47	39	40	41	41
Lumens per foot (305mm)	266	275	280	280	230	237	242	244
Watts per foot (305mm)	6.0	6.0	6.0	6.0	6.0	6.0	6.0	6.0

High Output (HO)

Efficacy - Lumens per Watt	42	43	44	44	36	37	38	38
Lumens per foot (305mm)	506	522	533	533	436	450	459	464
Watts per foot (305mm)	12.3	12.3	12.3	12.3	12.3	12.3	12.3	12.3

Performance | Zipper Board Optics

Zipper Board Optics design has 72 diodes per foot (305mm).

85° Asymmetric, black finish (A1-BL)

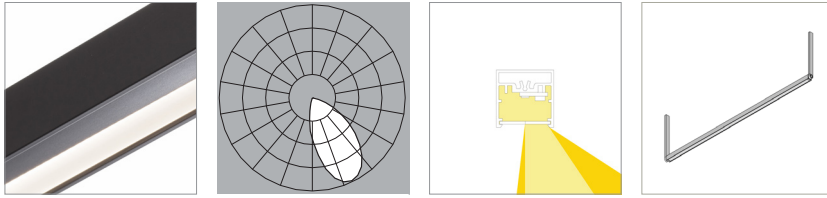

L80 >60,000 hours

	80 CRI (80min., 84 avg.)				90 CRI (90min., 96 avg.)			
	2700K	3000K	3500K	4000K	2700K	3000K	3500K	4000K
Low Output (LO)								
Efficacy - Lumens per Watt	52	53	54	54	44	46	47	47
Lumens per foot (305mm)	176	182	186	186	152	157	160	162
Watts per foot (305mm)	3.5	3.5	3.5	3.5	3.5	3.5	3.5	3.5
Standard Output (SO)								
Efficacy - Lumens per Watt	60	61	63	63	51	53	54	55
Lumens per foot (305mm)	353	364	371	371	304	314	320	323
Watts per foot (305mm)	6.0	6.0	6.0	6.0	6.0	6.0	6.0	6.0
High Output (HO)								
Efficacy - Lumens per Watt	55	57	58	58	48	49	50	51
Lumens per foot (305mm)	670	691	705	705	578	596	608	614
Watts per foot (305mm)	12.3	12.3	12.3	12.3	12.3	12.3	12.3	12.3

Performance | Button Board Optics

Button Board Optics design has 72 diodes per foot (305mm).

19° x 48° Oval (19)

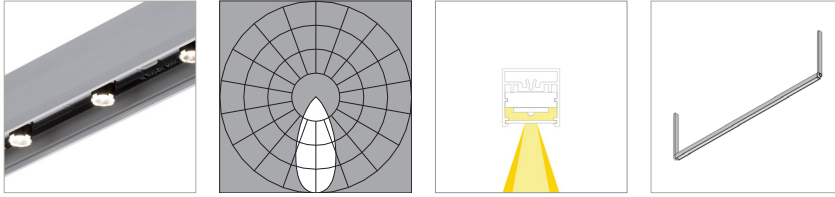

L80 >70,000 hours

80 CRI (80min., 84 avg.)

Standard Output (SO)	2700K	3000K	3500K	4000K
Efficacy - Lumens per Watt	61	64	67	69
Lumens per foot (305mm)	423	441	460	478
Watts per foot (305mm)	6.9	6.9	6.9	6.9

High Output (HO)

Efficacy - Lumens per Watt	55	57	60	62
Lumens per foot (305mm)	648	673	701	729
Watts per foot (305mm)	11.7	11.7	11.7	11.7
	-	-	83	-

36° Medium (36)

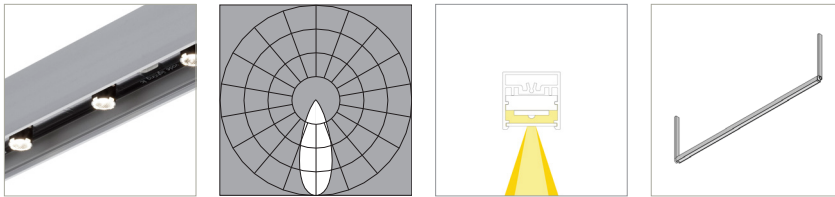

L80 >70,000 hours

80 CRI (80min., 84 avg.)

Standard Output (SO)	2700K	3000K	3500K	4000K
Efficacy - Lumens per Watt	71	74	78	80
Lumens per foot (305mm)	492	513	534	556
Watts per foot (305mm)	6.9	6.9	6.9	6.9

High Output (HO)

Efficacy - Lumens per Watt	64	66	70	72
Lumens per foot (305mm)	747	778	810	843
Watts per foot (305mm)	11.7	11.7	11.7	11.7

Copyright © 2022 Vode Lighting LLC. All rights reserved. Vode, the Vode logo, BoxRail, FlyWing, MicroBaffle, Button Board, Zipper Board, Zero Canopy, Zero Block, VodeNODE and other names are either registered trademarks or trademarks of Vode Lighting LLC in the United States and may be registered in other countries. All other trademarks listed herein belong to their respective owners. Due to ongoing innovation, specification details may change without notice.