

Surface Mount | 707 | ZipTwo® | Remote Power | Magnet with Tape-On Metal Strip | vodeCONNECT™

Please read instructions in their entirety before proceeding with any part of the installation. This product must be installed in accordance with the applicable installation code by a person familiar with the construction and operation of the product and the hazards involved. Consult a qualified electrician to ensure correct branch circuit rating. To prevent electric shock, disconnect all power before installing or servicing product. Rated for use in dry and damp locations only. Retain instructions for future reference.

Technical Support: 707.996.9898 or technicalsupport@vode.com

Installed View

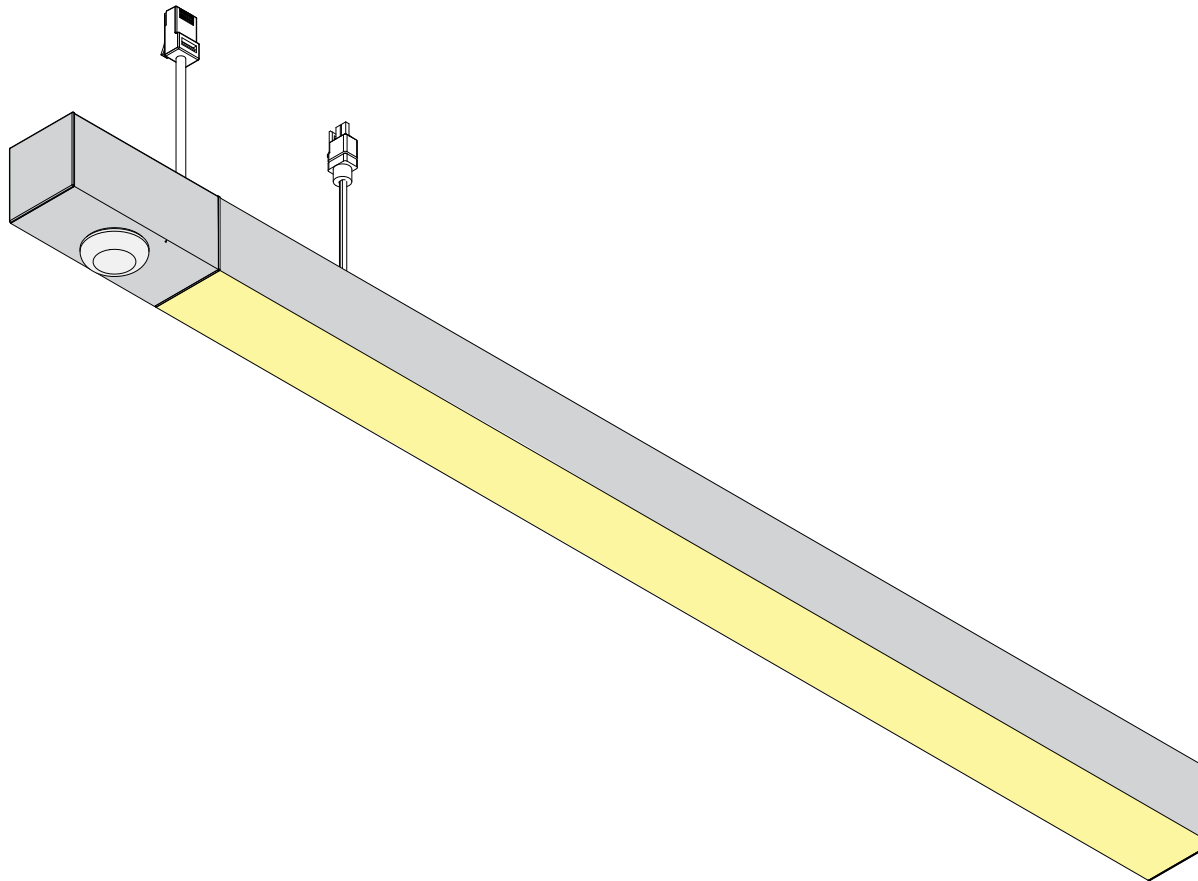

Parts Diagram

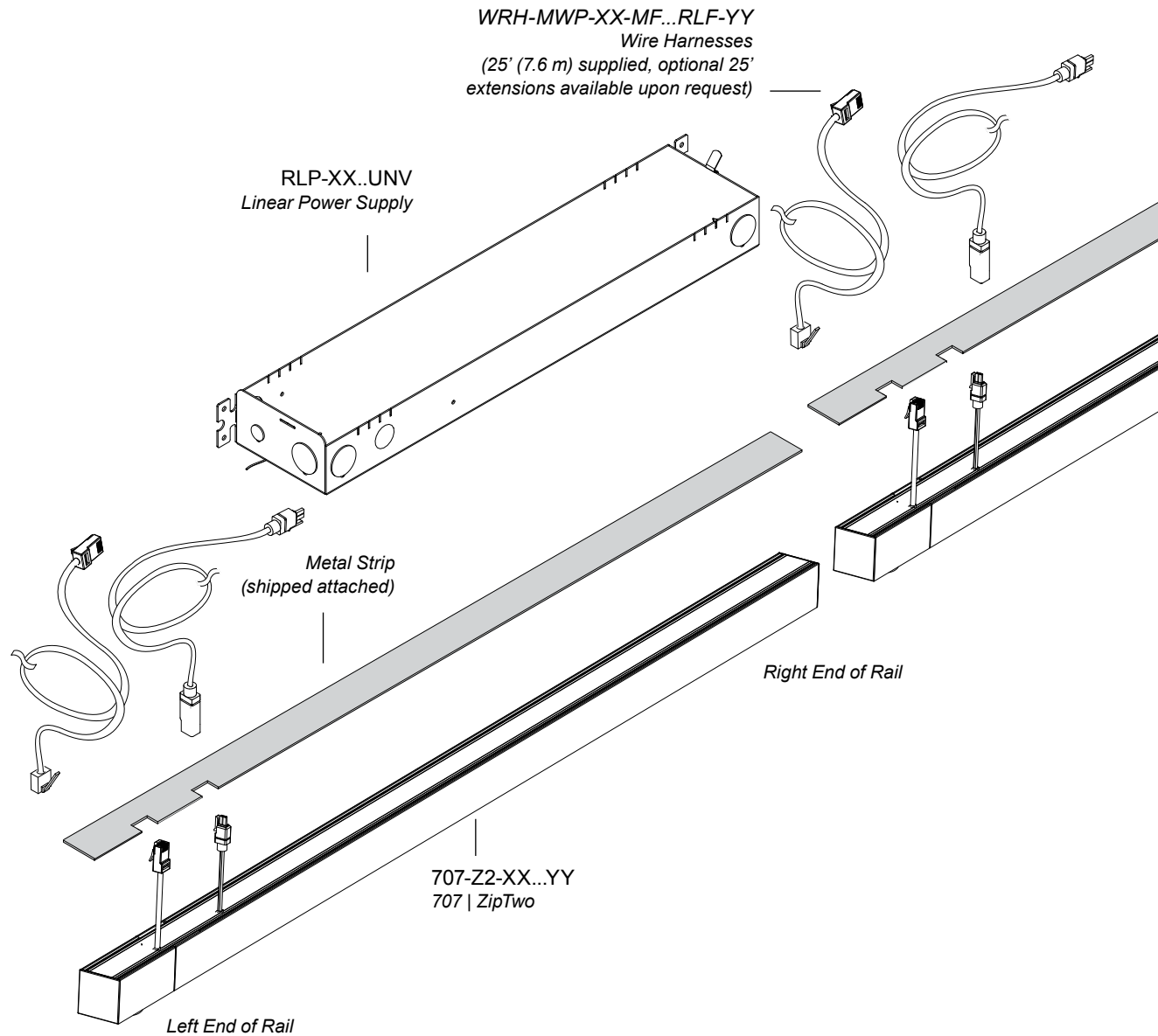

Fixture Orientation

Power feeds come out of the bottom of the fixture as shown. Refer to Power Feed Distance Table for dimensions from power feed to end of fixture.

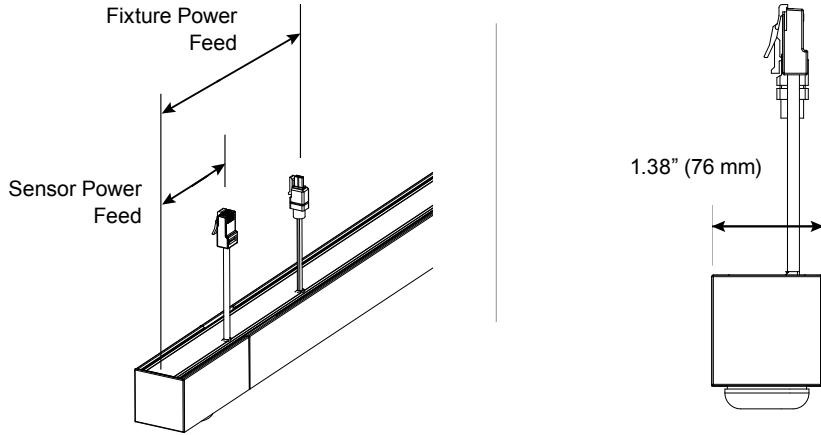

Power Feed Distance From End of Fixture

Sensor	Sensor Power Feed	Fixture Power Feed
Enlighted Micro Sensor	2.7" (68.6 mm)	6.2" (157.5 mm)
Encelium SensiLUM	2.7" (68.6 mm)	6.2" (157.5 mm)
Legrand Wattstopper	2.7" (68.6 mm)	6.2" (157.5 mm)
Lutron Athena	2.7" (68.6 mm)	6.2" (157.5 mm)
Lutron Vive	2.7" (68.6 mm)	6.2" (157.5 mm)
nLight Air	2.7" (68.6 mm)	6.2" (157.5 mm)
nLight Wired	5.3" (134.6 mm)	9' (228.6 mm)

Sensor Power Cable Type

Sensor	Sensor Power Cable Type
Enlighted Micro Sensor	Cat 5e Cable
Encelium SensiLUM	4 Conductor Wire Harness
Legrand Wattstopper	2 Conductor Wire Harness
Lutron Athena	4 Conductor Wire Harness
Lutron Vive	2 Conductor Wire Harness
nLight Air	4 Conductor Wire Harness
nLight Wired	Cat 5e Cable

ZipTwo Magnet with Tape-On Metal Strip Installation

Determine fixture and sensor wire harness locations and drill 1/2" (13mm) hole in mounting surface. Feed low voltage wire harness into remote power housing. Connect supplied plenum rated wire harness to pre-installed wire harnesses on remote power supply. Leave approximately 1" of wire harness hanging out.

IMPORTANT: Fixture **MUST** be installed to provided ferrous strip for proper installation. Surface must be clean, dry and flat before adhering provided strip.

Remove tape-on metal strip backing and carefully apply to the desired surface. Once alignment is exactly as desired, press firmly along the length of the strip to ensure it properly secured. Connect fixture wire harness to power wire harness.

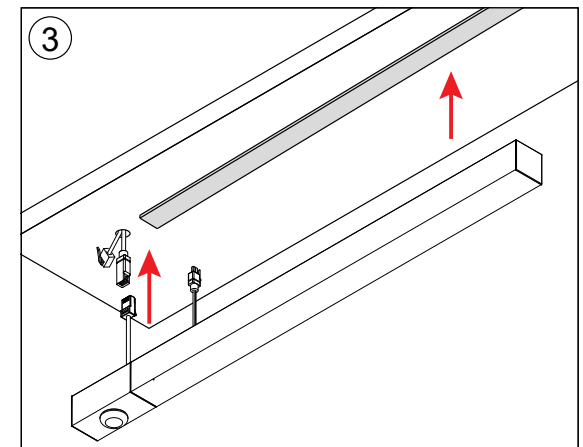
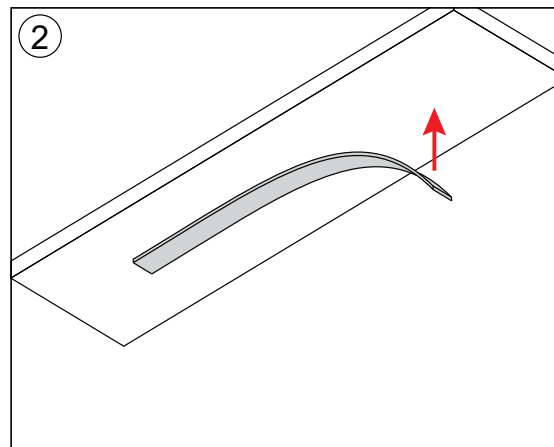
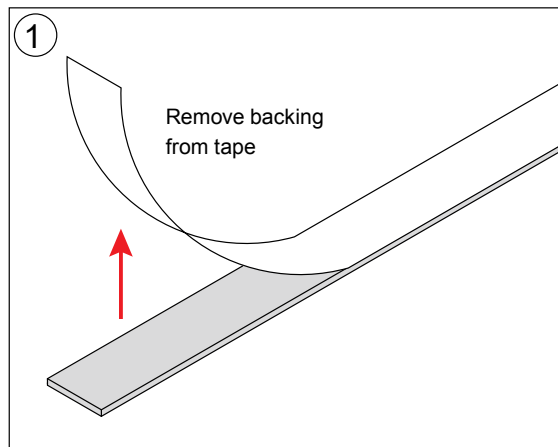

Install Remote Linear Power Supply

IMPORTANT! Before installing any power supply, turn off electricity at circuit box.

Vode recommends keeping track of which lids comes with which housing, as the lid contains important installation labeling.

Using the indicated tab, remove power housing lid to access mounting points. Install power supply housing to desired surface using screws (*provided by others*). Run line, ground and neutral wiring and any applicable dimming controls into power housing through any provided knockout and secure in place, using conduit as necessary per local coding. Use wire nuts (*provided by others*) to make a secure connection between all wiring. (*The provided wire leads are 18 AWG solid core*).

Refer to sensor manufacturer’s install guide for detailed sensor calibration and configuration instructions.

DO NOT power on system until instructed.

For remote power supply maximum distance or other wiring questions, please consult Vode Power Guide.

NOTE: If power housing is supplied pre-wired with cord and plug and wire harness installed, skip above steps and power system when instructed by plugging system into a standard outlet.

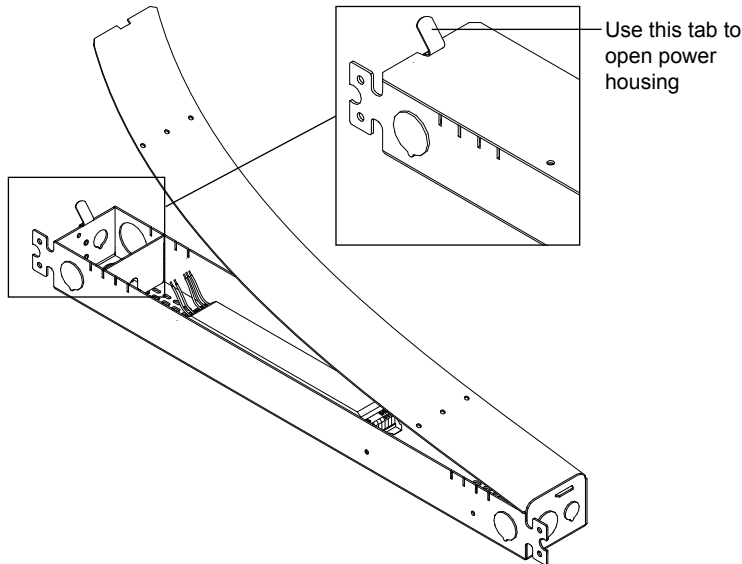

Remote Driver Distance

All Vode linear remote drivers come in a 0.054” (1.4 mm) formed galvanized steel power supply housing with five (5) knockouts: (4) 1-1/8”, (1) 7/8” and (1) 9/16”. Power supply housing dimensions: 2 3/8” (56 mm) x 1 5/8” (33 mm) x 20 11/16” (525 mm)

Driver	Remote Distance
eldoLED	100’ (30.5 m)
Lutron	See Power Guide
Magnitude	100’ (30.5 m)
OSRAM	100’ (30.5 m)

For other wiring questions and driver specific information, see **Vode Remote Power Guide**.

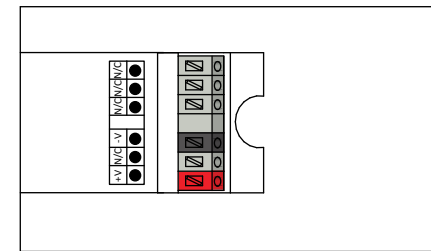

Example Only
See Vode Remote Power Guide for wiring detail.

Sensor	Remote Distance
Enlighted Micro Sensor	100’ (30.5 m)
Encelium SensiLUM	100’ (30.5 m)
Legrand Wattstopper	100’ (30.5 m)
Lutron Athena	100’ (30.5 m)
Lutron Vive	60’ (18.3 m)
nLight Air	100’ (30.5 m)
nLight Wired	100’ (30.5 m)

A 0-10V driver with control unit

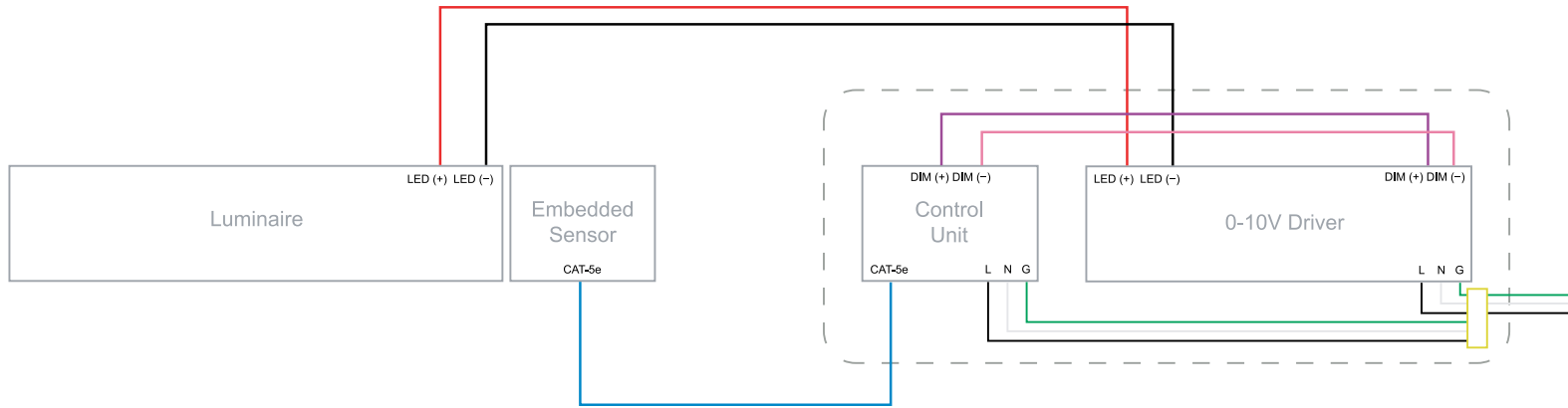

B DALI D4i driver without control unit, 2-wire sensor kit



A 0-10V driver with AUX, no control unit

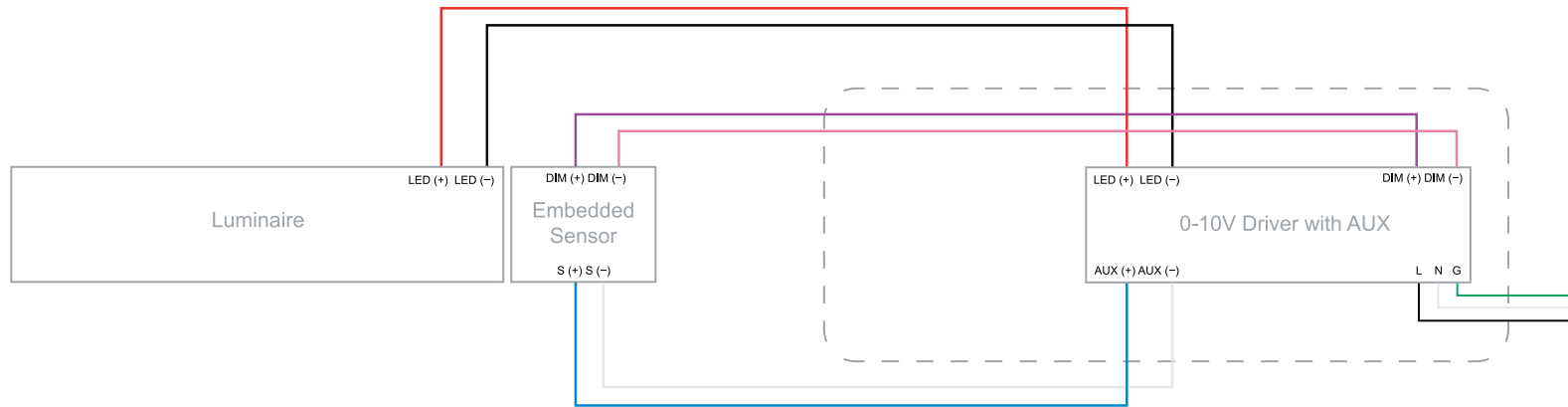

B DALI D4i driver without control unit

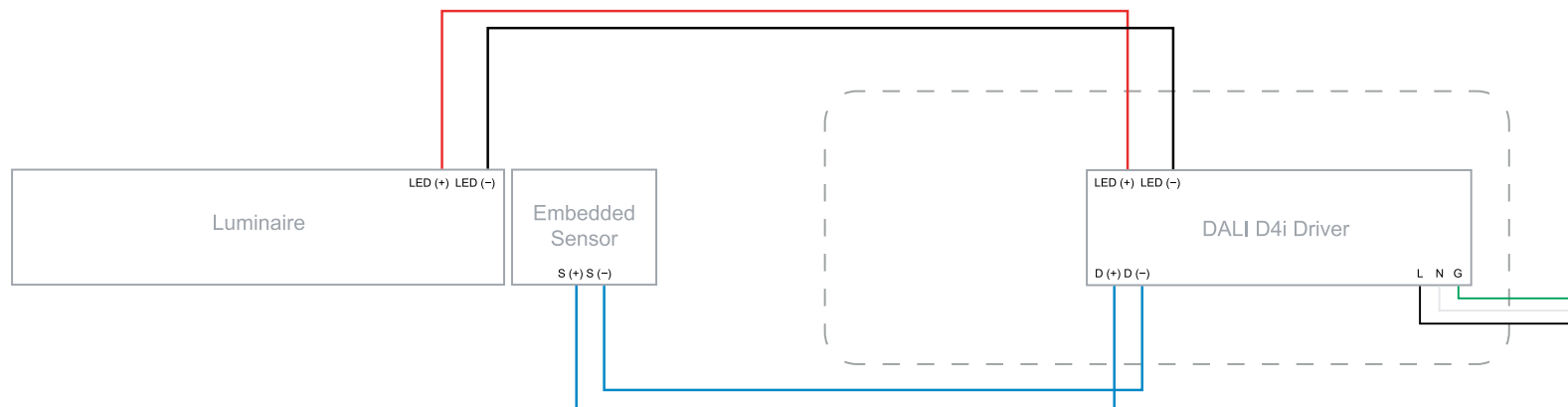

C 0-10V driver with control unit

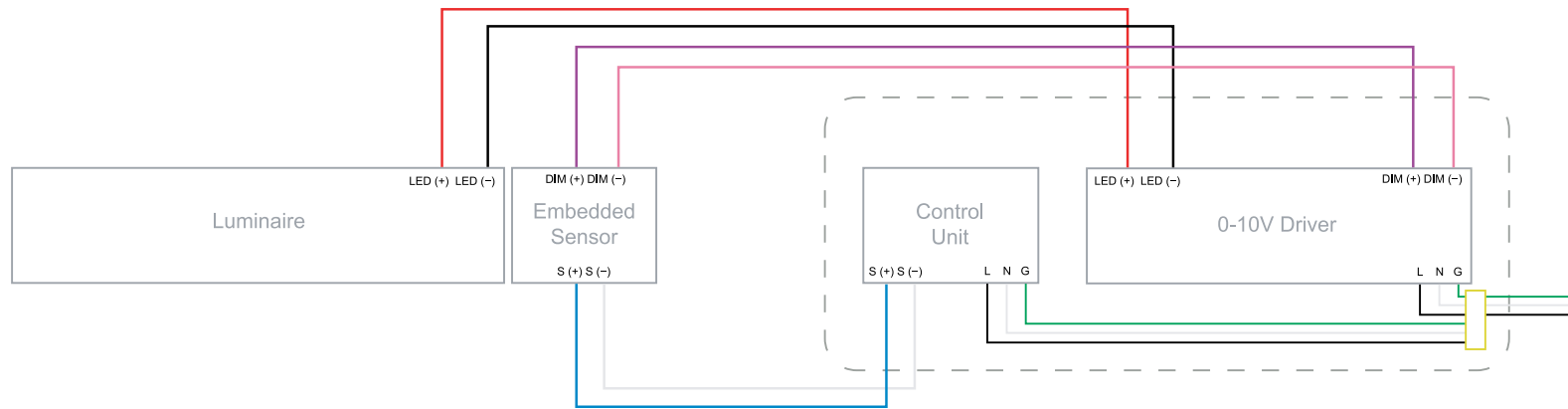

A 0-10V driver with control unit

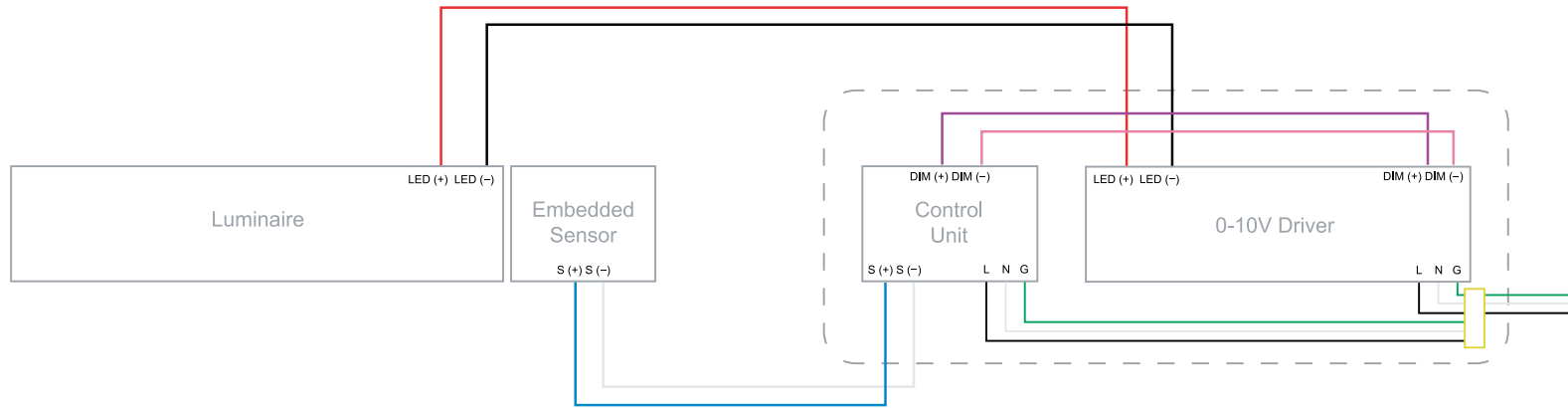

B DALI D4i driver without control unit



A Lutron Ecosystem or DALI driver with control unit

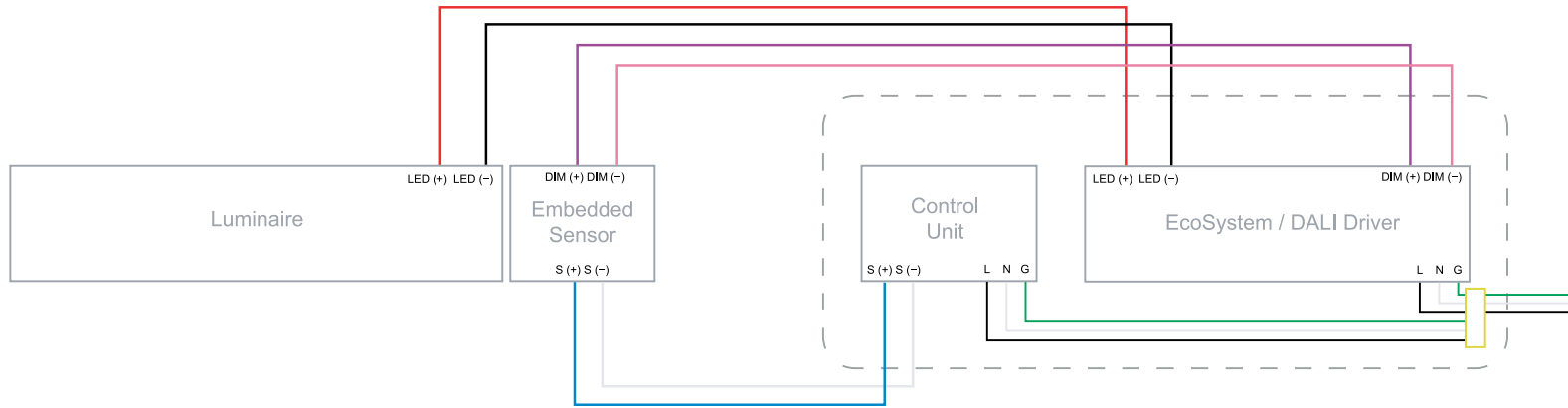

B 0-10V driver with control unit

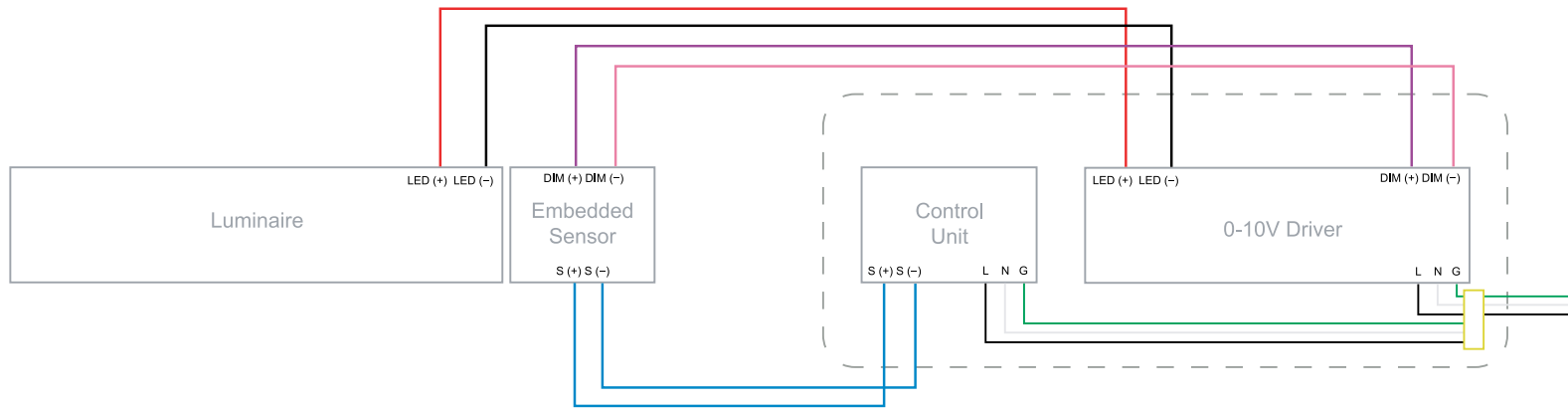

C DALI D4i driver without control unit

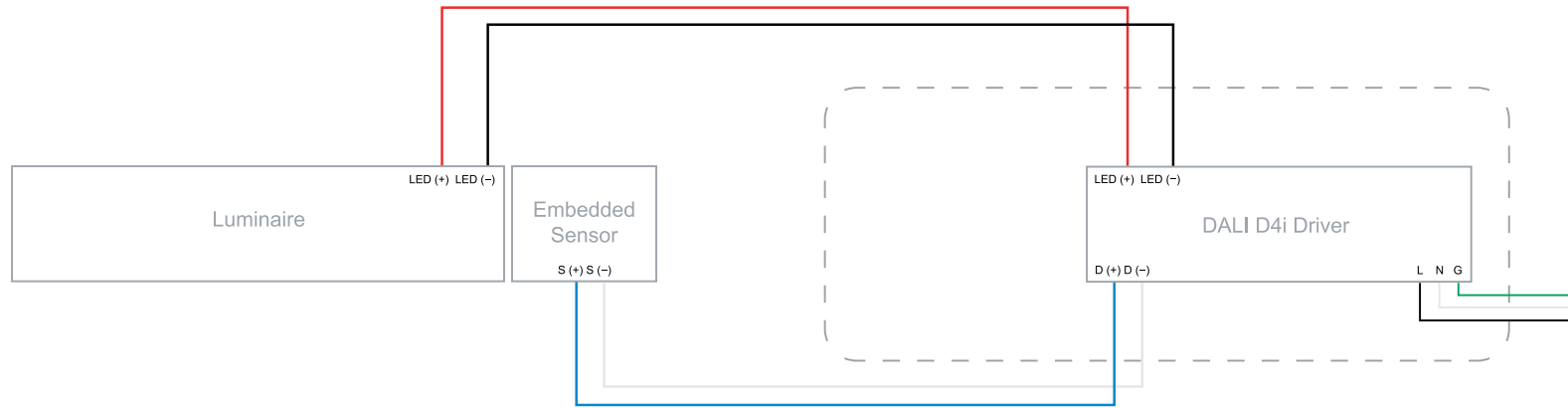

D 0-10V driver with AUX, no control unit

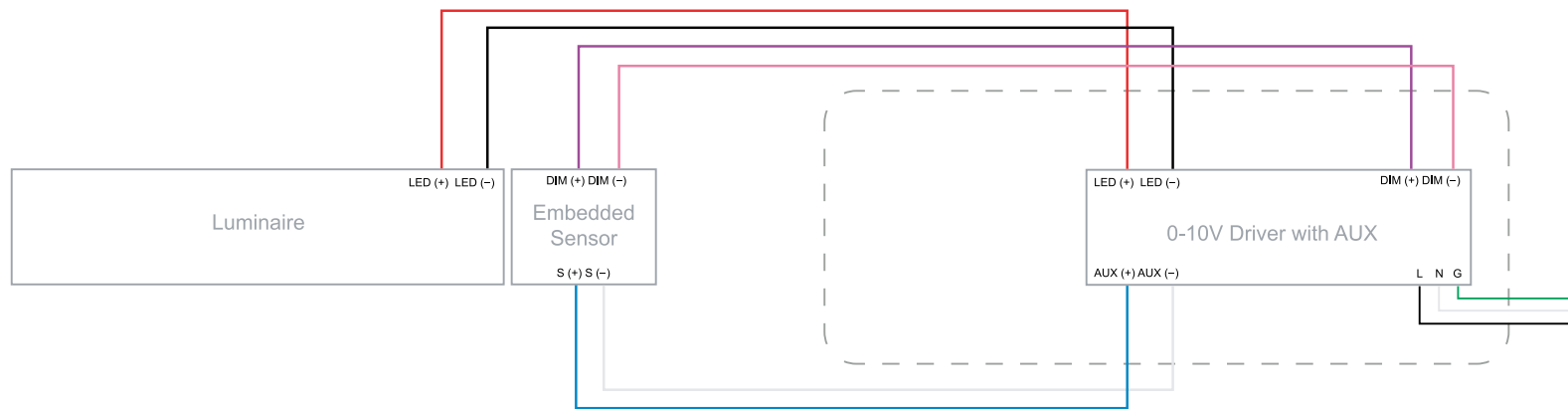

E 0-10V driver with AUX, node only

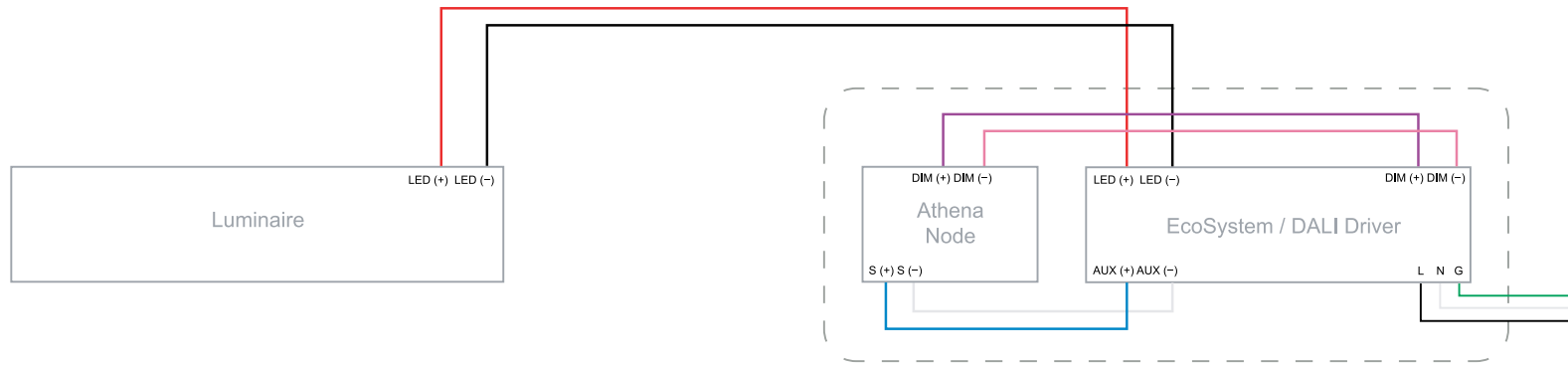

F D4i driver, node only

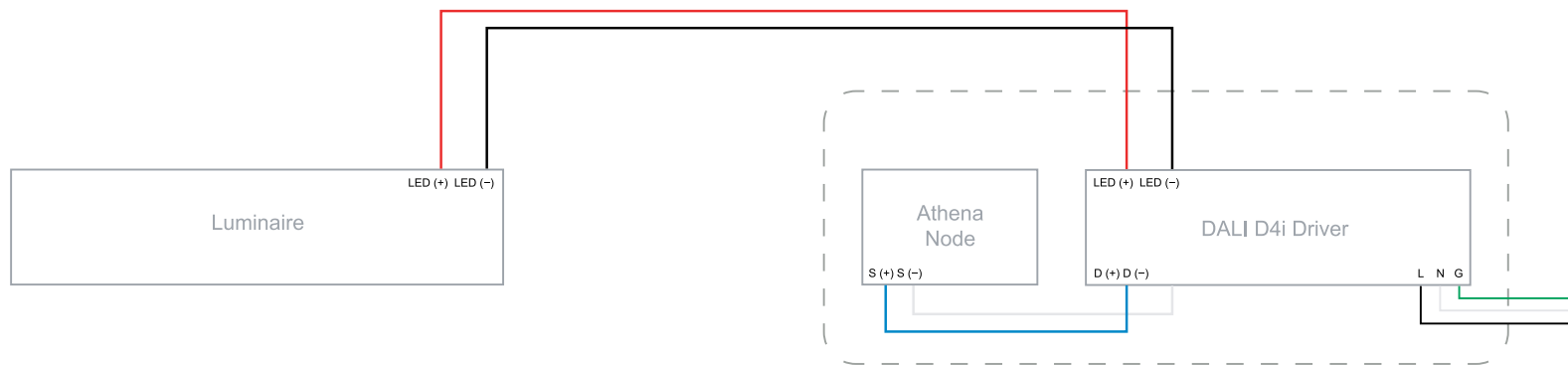

A Lutron Ecosystem or DALI driver with control unit

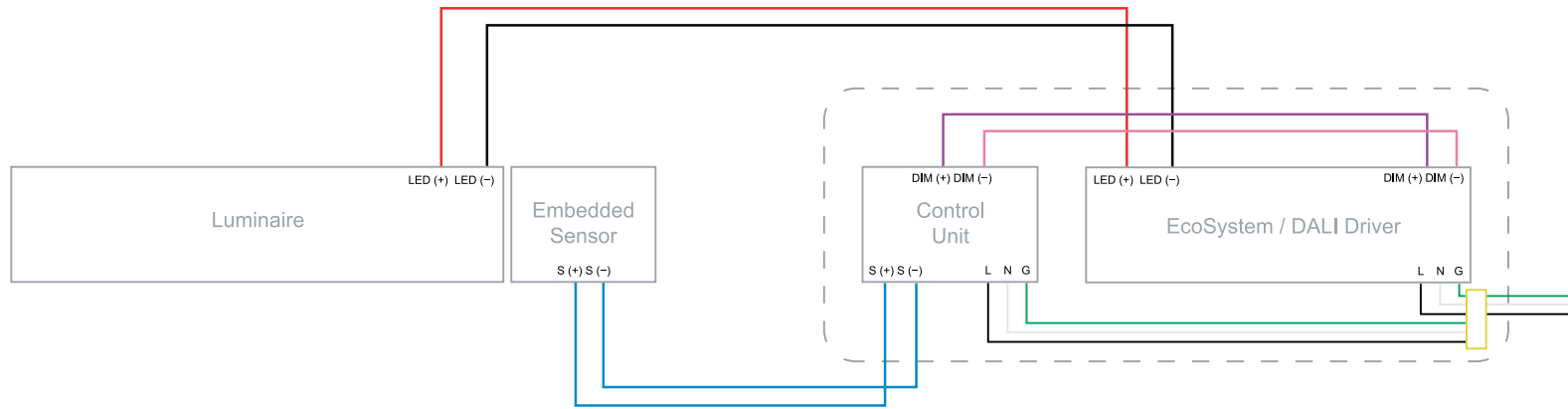

B DALI D4i driver without control unit

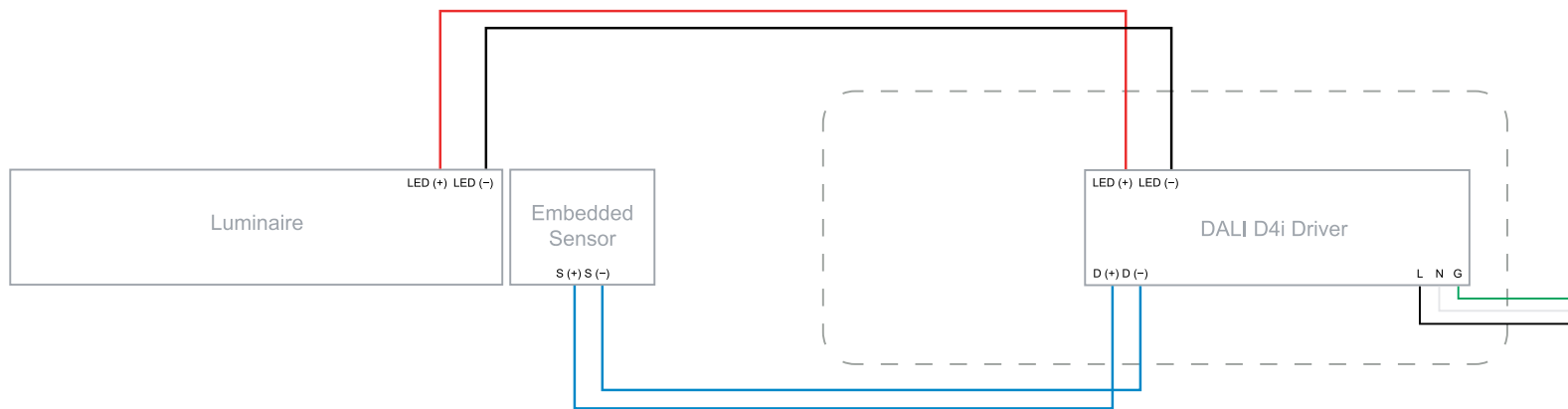

A 0-10V driver with AUX, no control unit

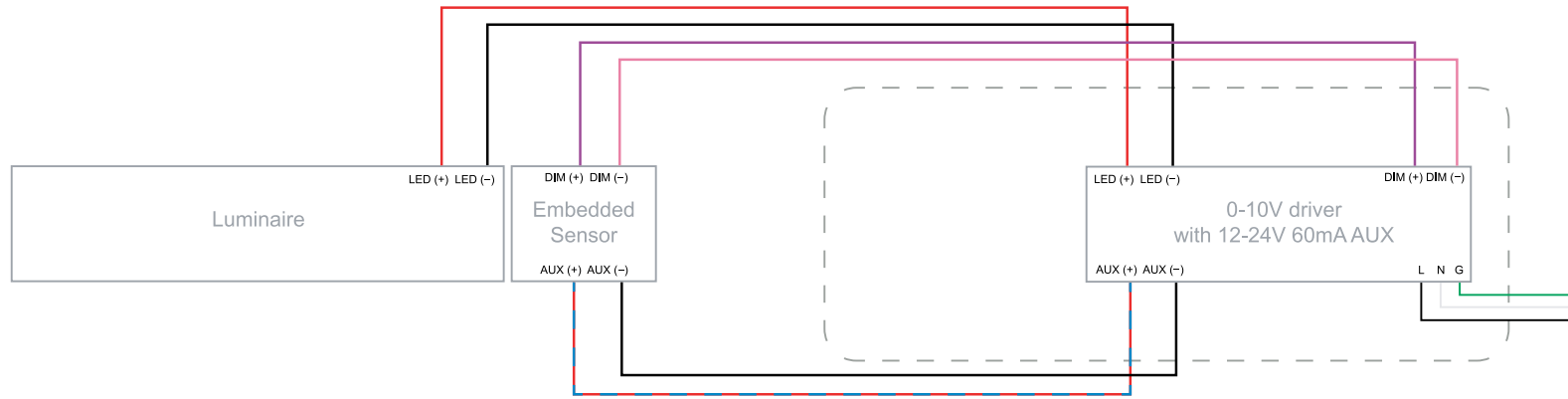

B 0-10V driver with power supply

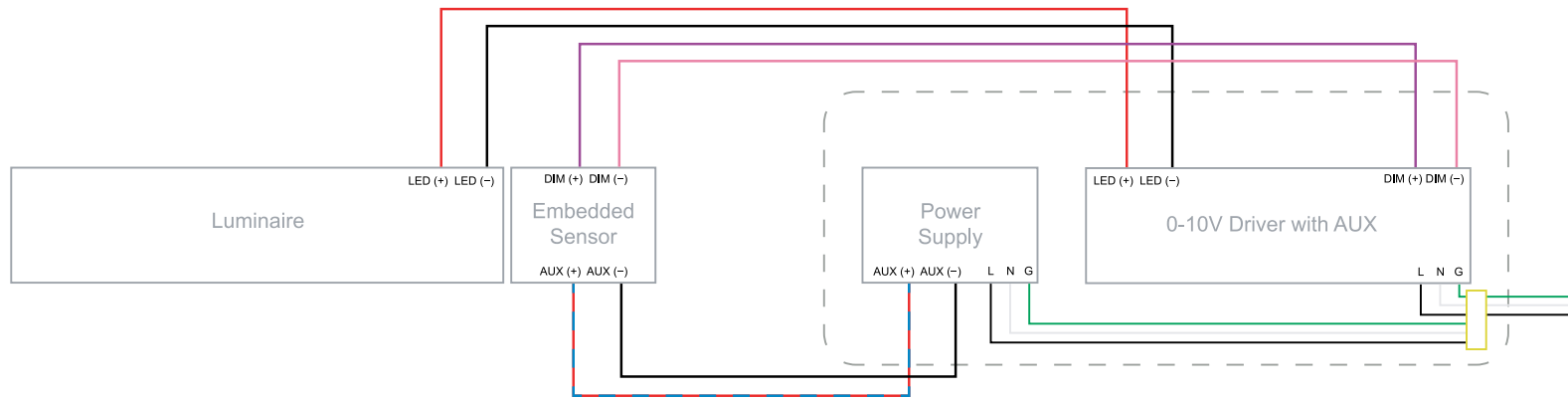

A LEDcode intensity dimming powered by driver AUX

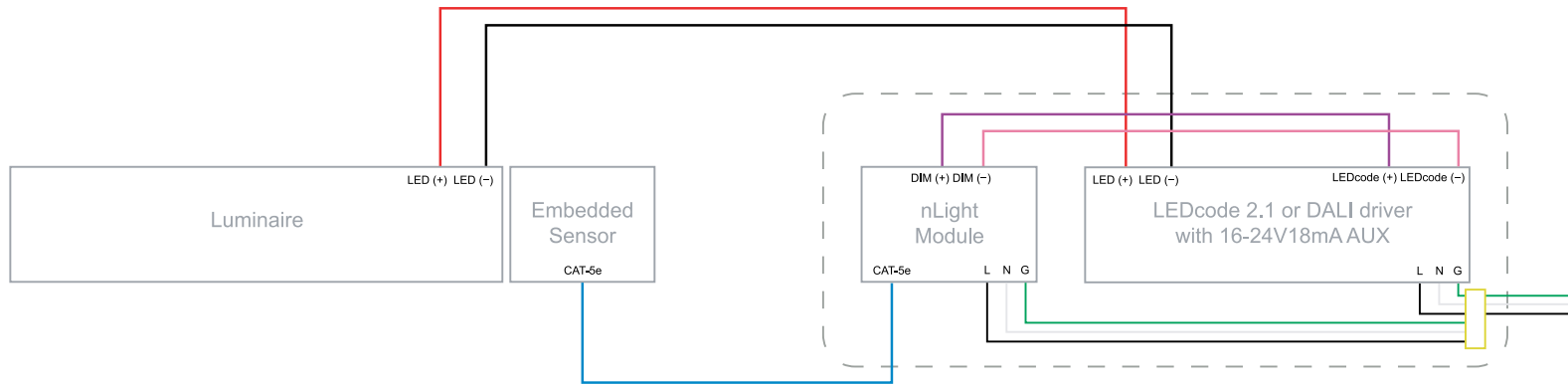

B 0-10V intensity dimming powered by driver AUX

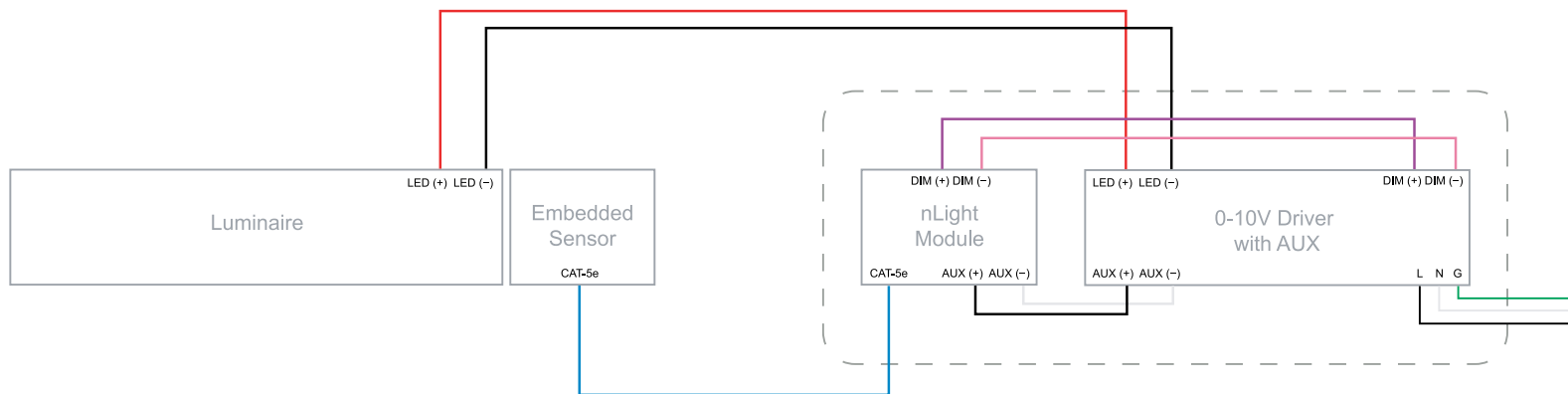

C 0-10V driver with control unit

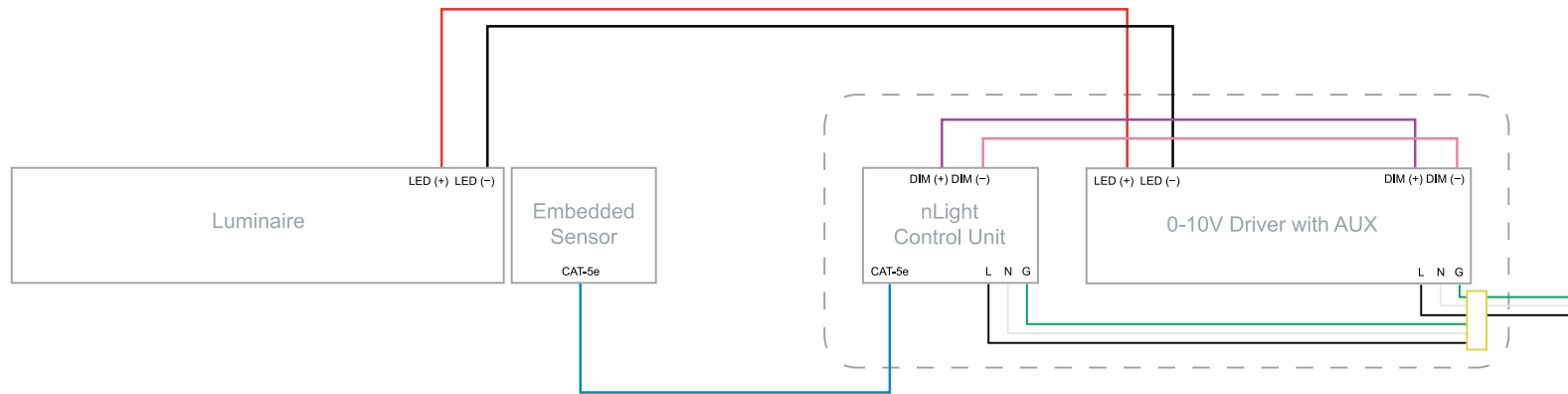

Troubleshooting Guide

My fixture will not turn on:

Check all wiring is correct and all connections are fastened properly.

If all wiring is correct, remove fixture and connect it to a known working driver.

If the fixture lights up, then the problem is with the installed driver or wiring:

- 1) Check line voltage to driver is present.
- 2) Check driver wiring (see **Vode Power Guide** for details) and check wiring to fixture.

If fixture still doesn't light up, check that all dimming wires are installed correctly. Reversed polarity on any driver will cause the entire system to not work, (see **Vode Power Guide** for wiring details).

The fixture is not dimming properly:

Check all wiring is correct and all connections are fastened properly.

Check driver and sensor control wiring (see **Vode Power Guide**, **vodeCONNECT Brochure**) and the sensor control manufacturer's website for further details).

For any help with installation or technical information, contact Vode Tech Service at 707-996-9898.

Important Notes

- Listed to UL standards for damp location by a Nationally Recognized Testing Laboratory (NRTL) recognized by OSHA
- Power Type: Class 2 (<60v) constant current driver.
- Dimming curve is factory preset to linear. Logarithmic is available upon request. See Vode Driver Guide for specific details and wiring diagram.
- Unless specified, one driver and one sensor per rail will be supplied.
- Please consult sensor manufacturer's product technical sheets for additional information.
- 5 Year Limited Warranty. All material and component parts manufactured by Vode are guaranteed to be free from defects of material and/or workmanship for a period of 5 years from date of sale. Product must be installed according to Vode installation instructions and accepted trade practices. Power supplies and other auxiliary equipment are not covered under Vode warranty but may be covered by separate OEM warranty.